



## **Model 600-000**

### **XL-AK Time and Frequency Receiver**

**Serial No.** \_\_\_\_\_

**September 17, 2001**  
**Revision A**

# MODEL 600-000

## Installed Options Checklist

### GPS-XL MODULE OPTION(S)

**87-810-3**

- Down Converter
- TTL Time Code Output       IRIG-B       IRIG-E       IRIG-H
- TTL Frequency Output(s)       10 MPPS       5 MPPS       1 MPPS
- SINE Frequency Output(s)       10 MHz       5 MHz       1 MHz
- Alarm Output (open collector)
- Precision 60pps Output
- Slow Code Output
- Programmable Pulse Output (PPO)
- External 1pps Time Interval/Event Timing Input (TI-ET)
- External Frequency Measurement Input (FREQ MEAS)
- External Oscillator Control (includes Parameter Entry/Request)
- RS-422 or RS-485 Serial Interface (replaces standard RS-232 Interface)

### ADDITIONAL OPTION(S)

- Power Supply Option      Manual Section X
- Disciplined High Stability Quartz Oscillator      Manual Section XV
- 10 MHz Low Phase Noise Output(s)      Manual Section XVI
- Disciplined Quartz Oscillator      Manual Section XVII
- Differential GPS Input      Manual Section XXI
- Auxiliary Reference Input      Manual Section XXII

### SPECIAL OPTION(S) DOCUMENTATION

- Manual Section X      Manual Section X



3750 Westwind Boulevard  
Santa Rosa, California 95403

t 707.528.1230  
f 707.527.6640  
w www.truetime.com

## FCC Notice and Compliance Statement

**Model:**                    **Fiber Optic Modules, 150-702-1**  
                                 **Fiber Optic Modules, 150-704-1**  
                                 **XL-AK GPS Receiver, 600-000**  
                                 **XL-AK GPS Receiver, 600-100**  
                                 **XL-AK GPS Receiver, 600-101**  
                                 **Network Time Server, NTS-200**  
                                 **Antenna Down\Up Converter, 142-6150**

### FCC Notice

This device has been tested and found to comply with the limits for a Class B digital device, pursuant to Part 15 of the FCC Rules. These limits are designed to provide reasonable protection against harmful interference in a residential installation. This device generates, uses, and can radiate radio frequency energy and, if installed and used in accordance with the instruction manual, may cause harmful interference to radio communications. However, there is no guarantee that interference will not occur in a particular installation. If this device does cause harmful interference to radio or television reception, the user is encouraged to try to correct the interference by one or more of the following measures:

- Reorient or relocate the receiving antenna.
- Increase the separation between the computer and receiver.
- Connect the computer into an outlet on a circuit different from that to which the receiver is connected.
- Consult the dealer or an experienced radio/TV technician for help.

Caution: Any changes or modifications not expressly approved by the grantee of this device could void the user's authority to operate the equipment.

### FCC Compliance Statement

This device complies with Part 15 of the FCC rules. Operation is subject to the following two conditions: (1) this device may not cause harmful interference, and (2) this device must accept any interference received, including interference that may cause undesired operation.

# Declaration of Conformity

**Model: XL-AK GPS Receiver, 600-101**  
**XL-AK GPS Receiver, 600-000**  
**XL-AK GPS Receiver, 600-100.**

This product complies with the following European Union Directives:

89/392/EEC Safety of Machinery  
as amended by 91/368/EEC, 93/44/EEC, 93/68/EEC

89/336/EEC Electromagnetic Compatibility  
as amended by 92/31/EEC

73/23/EEC Low Voltage Safety  
as amended by 93/68/EEC, 94/C199/03, 95/C214/02

91/157/EEC Batteries & Accumulators  
as amended by 93/86/EEC

The following standards were used to verify compliance with the Directives:

EN50081-1 Class B, EN55011 Class B, EN55014, EN50082-1 Class B,  
IEC801-2, IEC801-3, IEC801-4

Approved by

  
\_\_\_\_\_  
R. Dielman, Vice President, Sales

  
\_\_\_\_\_  
M. Toppe, Vice President, Marketing

  
\_\_\_\_\_  
M. Korreng, Product Engineer

  
\_\_\_\_\_  
E. Rumphrey, Operations Manager

  
\_\_\_\_\_  
M. Von der Porten, Manager of Administrative Services

9 October 1997

## TABLE OF CONTENTS

SECTION	TITLE
<b><u>I</u></b>	<b><u>GENERAL INFORMATION</u></b>
1-1	INTRODUCTION
1-2	LIMITED WARRANTY
1-3	LIMITATION OF LIABILITY
1-4	PROPRIETARY NOTICE
1-10	PHYSICAL SPECIFICATIONS
1-11	ENVIRONMENTAL SPECIFICATIONS
1-12	POWER INPUT SPECIFICATIONS
1-13	BATTERY SPECIFICATIONS
1-14	TIMING/FREQUENCY PERFORMANCE SPECIFICATIONS
1-15	INTERFACE SPECIFICATIONS
1-20	GPS-XL INPUTS AND OUTPUTS
1-21	GPS-XL 1PPS OUTPUT (STANDARD)
1-22	GPS-XL IRIG-B OUTPUT (STANDARD)
1-30	GPS-XL TTL TIME CODE(s) IRIG-B, IRIG-E or IRIG-H (OPTION)
1-31	GPS-XL 1, 5, or 10 MPPS OUTPUT(s) (OPTION)
1-32	GPS-XL 1, 5, or 10 MHz OUTPUT(s) (OPTION)
1-33	GPS-XL 1KPPS OUTPUT (OPTION)
1-34	GPS-XL SLOW CODE OUTPUT (OPTION)
1-35	GPS-XL PRECISION 60PPS OUTPUT (OPTION)
1-36	GPS-XL ALARM OUTPUT-OPEN COLLECTOR (OPTION)
1-37	GPS-XL PROGRAMMABLE PULSE OUTPUT (OPTION)
1-38	EXTERNAL OSCILLATOR CONTROL DAC OUTPUT (OPTION)
1-50	EXTERNAL OSCILLATOR INPUT (OPTION)
1-51	TIME INTERVAL/EVENT TIMING INPUT (OPTION)
1-52	FREQUENCY MEASUREMENT INPUT (OPTION)
1-60	SERIAL INTERFACE
1-61	RS-232/RS-485 CONNECTION
1-62	SERIAL DATA FORMAT
1-63	EXCLUSIVE USE
<b><u>II</u></b>	<b><u>INSTALLATION</u></b>
2-1	OVERVIEW
2-2	PROCEDURE
2-3	SPECIAL CONSIDERATIONS FOR EXTERNAL OSCILLATOR CONTROL OPTION
2-4	RACK MOUNTING
<b><u>III</u></b>	<b><u>OPERATION</u></b>
3-1	INTRODUCTION
3-2	GENERAL OPERATION
3-3	XL-AK START-UP
3-4	SATELLITE ACQUISITION
3-10	OPERATIONAL MODES

## TABLE OF CONTENTS (Continued)

SECTION	TITLE
<b>III</b>	<b>OPERATION (Continued)</b>
3-11	AUTO MODE
3-12	SURVEY MODE
3-13	TIME MODE
3-20	TIME QUALITY INDICATION
3-21	FRONT PANEL INTERFACE
3-23	ALPHANUMERIC DISPLAY
3-24	TIME PUSH BUTTON
3-25	STATUS PUSH BUTTON
3-26	POSITION PUSH BUTTON
3-27	KEYPAD OPERATION
3-28	SELECTING FUNCTIONS AND ENTERING DATA
3-99	KEYPAD FUNCTION LIST
3-100	KEYPAD FUNCTION 00 - KEYPAD HELP FUNCTION
3-101	KEYPAD FUNCTION 01 - TIME ZONE ENTRY/REQUEST
3-102	KEYPAD FUNCTION 02 - 12/24 HOUR FORMAT ENTRY REQUEST
3-103	KEYPAD FUNCTION 03 - TIME/DATE ENTRY/REQUEST
3-104	KEYPAD FUNCTION 04 - SERIAL PORT SETUP
3-105	KEYPAD FUNCTION 05 - TIME QUALITY ENABLE/SETUP
3-106	KEYPAD FUNCTION 06 - KEYPAD LOCKOUT ENABLE
3-107	KEYPAD FUNCTION 07 - EXTERNAL OSCILLATOR ENABLE (OPTION)
3-113	KEYPAD FUNCTION 13 - WORST-CASE TIME ERROR REQUEST
3-114	KEYPAD FUNCTION 14 - EXTERNAL OSCILLATOR PARAMETER ENTRY/REQUEST (OPTION)
3-116	KEYPAD FUNCTION 16 - EMULATION MODE ENABLE
3-116.1	SERIAL PORT EMULATION COMMANDS
3-116.2	MODE C - CONTINUOUS TIME, ONCE PER SECOND
3-116.3	MODE F - FORMAT THE TIME MESSAGE
3-116.4	MODE R - RESET TO DEFAULT AND MODE C
3-116.5	MODE T - TIME ON REQUEST
3-117	KEYPAD FUNCTION 17 - SLOW CODE SETUP (OPTION)
3-118	KEYPAD FUNCTION 18 - SOFTWARE VERSION REQUEST
3-128	KEYPAD FUNCTION 28 - TIME INTERVAL/EVENT TIMING INPUT (OPTION)
3-129	KEYPAD FUNCTION 29 - FREQUENCY MEASUREMENT INPUT (OPTION)
3-131	KEYPAD FUNCTION 31 - BACKLIGHT ENABLE (OPTION)
3-150	KEYPAD FUNCTION 50 - POSITION ENTRY/REQUEST
3-151	KEYPAD FUNCTION 51 - ANTENNA CABLE DELAY ENTRY/REQUEST
3-152	KEYPAD FUNCTION 52 - DISTRIBUTION CABLE DELAY ENTRY/REQUEST
3-153	KEYPAD FUNCTION 53 - OPERATIONAL MODE ENTRY/REQUEST
3-155	KEYPAD FUNCTION 55 - ALTITUDE UNITS ENTRY/REQUEST
3-156	KEYPAD FUNCTION 56 - AVERAGE POSITION ENTRY/REQUEST
3-160	KEYPAD FUNCTION 60 - SATELLITES LIST REQUEST
3-165	KEYPAD FUNCTION 65 - SATELLITE SELECT

## TABLE OF CONTENTS (Continued)

SECTION	TITLE
<b>III</b>	<b>OPERATION (Continued)</b>
3-166	KEYPAD FUNCTION 66 - DAYLIGHT SAVING ENABLE
3-168	KEYPAD FUNCTION 68 - YEAR ENTRY (GPS EPOCH MANAGEMENT)
3-169	KEYPAD FUNCTION 69 - SELECT LOCAL/STANDARD/GPS/UTC TIME
3-171	KEYPAD FUNCTION 71 - OSCILLATOR STATISTICS REQUEST
3-172	KEYPAD FUNCTION 72 - FAULT STATUS REQUEST
3-173	KEYPAD FUNCTION 73 - REQUEST/SET ALARM STATUS/CONTROL
3-179	KEYPAD FUNCTION 79 - WARM START
3-197	GENERAL SERIAL INPUT AND OUTPUT FORMAT
3-198	SERIAL ERROR MESSAGES
3-199	SERIAL FUNCTION LIST
3-201	SERIAL FUNCTION F01 - TIME ZONE ENTRY/REQUEST
3-202	SERIAL FUNCTION F02 - 12/24 HR FORMAT ENTRY/REQUEST
3-203	SERIAL FUNCTION F03 - TIME/DATE ENTRY/REQUEST
3-205	SERIAL FUNCTION F05 - TIME QUALITY ENABLE/SETUP
3-206	SERIAL FUNCTION F06 - KEYPAD LOCKOUT ENABLE
3-207	SERIAL FUNCTION F07 - EXTERNAL OSCILLATOR ENABLE (OPTION)
3-208	SERIAL FUNCTION F08 - CONTINUOUS TIME ONCE PER SECOND ENABLE
3-209	SERIAL FUNCTION F09 - TIME ON REQUEST ENABLE
3-211	SERIAL FUNCTION F11 - TIME OUTPUT FORMAT ENTRY/REQUEST
3-213	SERIAL FUNCTION F13 - WORST-CASE TIME ERROR REQUEST
3-214	SERIAL FUNCTION F14 - EXTERNAL OSCILLATOR PARAMETER ENTRY/REQUEST (OPTION)
3-215	SERIAL FUNCTION F15 - EXCLUSIVE USE ENABLE
3-217	SERIAL FUNCTION F17 - SLOW CODE SETUP (OPTION)
3-218	SERIAL FUNCTION F18 - SOFTWARE VERSION REQUEST
3-226	SERIAL FUNCTION F26 - PROGRAMMABLE PULSE OUTPUT
3-228	SERIAL FUNCTION F28 - TIME INTERVAL/EVENT TIMING INPUT (OPTION)
3-229	SERIAL FUNCTION F29 - FREQUENCY MEASUREMENT INPUT (OPTION)
3-250	SERIAL FUNCTION F50 - POSITION ENTRY/REQUEST
3-251	SERIAL FUNCTION F51 - ANTENNA CABLE DELAY ENTRY/REQUEST
3-252	SERIAL FUNCTION F52 - DISTRIBUTION CABLE DELAY ENTRY/REQUEST
3-253	SERIAL FUNCTION F53 - OPERATIONAL MODE ENTRY/ REQUEST
3-255	SERIAL FUNCTION F55 - ALTITUDE UNITS ENTRY/ REQUEST
3-256	SERIAL FUNCTION F56 - AVERAGE POSITION ENTRY/ REQUEST
3-260	SERIAL FUNCTION F60 - SATELLITES LIST REQUEST
3-265	SERIAL FUNCTION F65 - SATELLITE SELECTION
3-266	SERIAL FUNCTION F66 - DAYLIGHT SAVING ENABLE
3-268	SERIAL FUNCTION F68 - YEAR ENTRY (GPS EPOCH MANAGEMENT)
3-269	SERIAL FUNCTION F69 - SELECT LOCAL/STANDARD/GPS/UTC TIME
3-271	SERIAL FUNCTION F71 - OSCILLATOR STATISTICS REQUEST
3-272	SERIAL FUNCTION F72 - FAULT STATUS REQUEST
3-273	SERIAL FUNCTION F73 - REQUEST/SET ALARM STATUS/CONTROL
3-279	SERIAL FUNCTION F79 - WARM START

## TABLE OF CONTENTS (Continued)

<b>SECTION</b>	<b>TITLE</b>
<b>IV</b>	<b>NOT USED</b>
<b><u>V</u></b>	<b><u>86-690 OUTPUT CONFIGURATION “L” BOARD</u></b>
5-1	86-690 “L” BOARD INTRODUCTION
5-2	SIGNAL SPECIFICATIONS
5-3	SIGNAL CONFIGURATION
FIGURE 1	CONFIGURATION HEADER
5-4	GENERAL OPERATION
5-5	THEORY OF OPERATION
<b><u>VI</u></b>	<b><u>CONFIGURATION/ASSEMBLY DRAWINGS</u></b>
<b>VII</b>	<b>NOT USED</b>
<b><u>VIII</u></b>	<b><u>IRIG-B, IRIG-H, AND IRIG-E TIME CODE FORMATS</u></b>
8-1	INTRODUCTION
8-2	IRIG CODE FORMAT
8-3	WORST-CASE TIME ERROR FLAGS
8-10	SPECIAL IRIG-B TIME CODE FORMAT (EMBEDDED GPS DATA OPTION)
FIGURE 8-1	IRIG-B TIME CODE
FIGURE 8-2	IRIG-E TIME CODE
FIGURE 8-3	IRIG-H TIME CODE
<b><u>IX</u></b>	<b><u>POWER SUPPLY OPTION</u></b>
<b><u>X</u></b>	<b><u>SPECIAL OPTION DOCUMENTATION</u></b>
<b><u>XIV</u></b>	<b><u>DISCIPLINED RUBIDIUM OSCILLATOR OPTION</u></b>
<b><u>XV</u></b>	<b><u>DISCIPLINED HIGH STABILITY QUARTZ OSCILLATOR OPTION</u></b>
<b><u>XVI</u></b>	<b><u>LOW PHASE NOISE OUTPUT OPTION</u></b>
<b><u>XVII</u></b>	<b><u>DISCIPLINED QUARTZ OSCILLATOR OPTION</u></b>
<b><u>XVIII</u></b>	<b><u>DISCIPLINED HP5071 CESIUM OSCILLATOR OPTION</u></b>
<b><u>XIX</u></b>	<b><u>DISPLAY BACKLIGHT OPTION</u></b>
<b><u>XXI</u></b>	<b><u>DIFFERENTIAL GPS INPUT OPTION</u></b>
<b><u>XXII</u></b>	<b><u>AUXILIARY REFERENCE INPUT OPTION</u></b>
<b><u>XXV</u></b>	<b><u>FIBER OPTIC LINK OPTION</u></b>



## SECTION I

### GENERAL INFORMATION

#### **1-1 INTRODUCTION**

This manual provides the user of a Model XL-AK-600 or XL-AK-601 Time and Frequency Receiver all of the information necessary to properly install, operate, and utilize all of its features. NOTE: Assembly and/or schematic drawings that may be included in this manual will be identified as 600-100 for the XL-AK-600 units and 600-101 for the XL-AK-601 units. *Only Maintenance manuals will include schematic drawings.* Model XL-AK-600 units do not have a front panel keypad or display.

The information in this manual includes normal installation procedures as well as any maintenance and adjustment data that may be required to facilitate field repairs.

The purpose of the Model XL-AK is to provide accurate time, frequency and position as derived from Coarse Acquisition (C/A) Link 1 (L1) signals transmitted by the NAVSTAR Global Positioning System (GPS) satellites. In addition it provides high resolution measurements of external time and frequency signals applied as inputs to the XL-AK versus the GPS reference. The XL-AK is usable on a world-wide basis under any weather conditions.

The XL-AK is completely automatic in satellite acquisition and time and frequency synchronization. When the unit is first installed (or if the unit is moved more than 100 km, or if the internal battery was discharged), acquisition time is shortened if the operator enters a position accurate to better than 100 kilometers (approximately one degree in latitude and longitude).

The XL-AK receiver will operate when the satellites are 10 degrees above the horizon and their signals are not obstructed. Whenever entered position information is less accurate than 10 meters, the XL-AK will first have to accurately ascertain its antenna position by tracking four or more satellites and performing a long term (24 hours) average of position fixes in order to maintain time and frequency accuracy and stability within specification. From that point on, the XL-AK will require only one satellite (above 10 degrees) to maintain valid time and frequency. However, operation to specified stability requires four or more satellites. When no satellites are in view, the XL-AK will continue to output its signals using either the internal or OPTIONAL external disciplined oscillator.

#### **1-2 LIMITED WARRANTY**

Each new product manufactured by TrueTime is warranted for defects in material or workmanship for a period of one year from date of shipment ("Limited Warranty"). Defects in material or workmanship found within that period will be replaced or repaired, at TrueTime's option, without charge for material or labor, provided the customer returns the equipment, freight prepaid, to the TrueTime factory under this limited warranty. TrueTime will return the repaired equipment, freight prepaid, to the customer's facility. This one year Limited Warranty does not apply to any software or to any product not manufactured by TrueTime.

If on-site warranty repair or replacement is required, the customer will be charged the then current field service rate for portal-to-portal travel time plus actual portal-to-portal travel charges. There is no charge for on-site warranty repair labor.

Products not manufactured by TrueTime but included as integral part of a system (e.g. peripherals, options) are warranted for 90 days, or longer as provided by the original equipment manufacturer, from date of shipment.

Aside from the Limited Warranty set forth above, TrueTime makes no other warranties, express or implied, of merchantability, fitness for purpose or of any other kind or description whatsoever.

By purchasing any product manufactured by TrueTime, the buyer consents to and agrees with TrueTime that as a result of the exclusion of all warranties, expressed or implied, of merchantability, fitness for purpose, or otherwise, except for the limited one-year warranty for defects in material and workmanship for products manufactured by TrueTime, that the Buyer has the sole responsibility to assess and bear all losses relating to: (1) the ability of the product or products purchased to pass without objection under the contract description among merchants and buyers in the trade; (2) the conformity of the product or products to fair average quality within its contract description; (3) the fitness of the product for the ordinary purposes for which such product is used; (4) the consistency of quality and quantity within each unit of product or products and among all units involved; (5) the adequacy of containers, packaging and labeling of the product or products; (6) the conformity of the product, promises or affirmations of fact (if any) made on its label or container; and (7) the conformity of the product to standards of quality observed by other merchants in the trade with respect to products of similar description.

### **1-3 LIMITATION OF LIABILITY**

By purchasing any product from TrueTime the Buyer consents to and agrees that the Buyer's sole and exclusive remedy for any damages or losses incurred by the Buyer as a result of TrueTime's breach of its one-year Limited Warranty for defects in materials and workmanship or otherwise in connection with any claim respecting the product shall be limited to the repair or replacement of the product or a refund of the sales price of the product.

In no event shall the Buyer be entitled to recover consequential damages or any other damages of any kind or description whatsoever.

### **1-4 PROPRIETARY NOTICE**

THIS DOCUMENT, WHETHER PATENTABLE OR NON-PATENTABLE SUBJECT MATTER, EMBODIES PROPRIETARY AND CONFIDENTIAL INFORMATION AND IS THE EXCLUSIVE PROPERTY OF TRUETIME, INC. IT MAY NOT BE REPRODUCED, USED OR DISCLOSED TO OTHERS FOR ANY PURPOSE EXCEPT THAT FOR WHICH IT IS LOANED, AND IT SHALL BE RETURNED UPON DEMAND.

1-5 through 1-9 reserved

## **1-10 PHYSICAL SPECIFICATIONS**

The XL-AK is a 19" rack-mounted product with the following physical specifications:

XL-AK Receiver Size: 1.75 in. x 17.0 in. x 10.5 in.  
(4.45 cm. x 43.18 cm. x 26.67 cm.)  
Standard 19" EIA Rack System, hardware included

Antenna Size (Bullet): 3.04 in. dia. x 2.94 in.  
(7.72 cm. dia. x 7.47 cm.)

Antenna Size (DSK): 2.625 in. dia. X 1.5 in.  
(Optional) (6.67 cm. dia. X 3.81 cm.)

Antenna/DownConverter Size: 2.625 in. dia. x 8.6 in.  
(Optional) (6.67 cm. dia. x 21.84 cm.)

NOTE: Antenna and Antenna/DownConverter Units are mounted on a 12 in. long PVC nipple with 3/4" Male Pipe Thread (MPT) on both ends. The above specified overall lengths of the Antenna and Antenna/DownConverter Units are therefore increased by approximately 11.25 in. when the mounting nipple is included.

XL-AK Receiver Weight: 7.0 lb max. (3.175 Kg)

Antenna Weight: 0.70 lb (.318 Kg)  
(Including mtg. nipple)

Antenna/DownConverter Weight: 2.35 lb (1.067 Kg)  
(Including mtg. nipple)  
(Optional)

Antenna Cable, RG-59: Standard length = 50 ft.  
1.2 lb (.545 Kg)

Antenna/DownConverter Cable, RG-58: Available lengths = 150 - 1500 ft.  
(Optional) 2.7 lb (1.23 Kg) per 100 ft.

## **1-11 ENVIRONMENTAL SPECIFICATIONS**

Operating Temperature:  
Antenna or Ant/DownConverter: -40° to +70° C (-40° to +158° F)  
XL-AK Receiver: 0° to +50° C (+32° to +122° F)

Storage Temperature:  
Antenna or Ant/DownConverter: -55° to +85° C (-67° to +185° F)  
XL-AK Receiver: -40° to +85° C (-40° to +185° F)

Humidity:  
Antenna or Ant/Down Converter: 100%, condensing  
XL-AK Receiver: 95%, non-condensing

### **1-12 POWER INPUT SPECIFICATIONS**

AC Power: 95-260 VAC, 47 to 440 Hz, < 15 W  
DC Power: 120-370 VDC, < 15 W  
(Optional)  
Power Fuse: Internal 2A, 5 x 20 mm (LITTELFUSE #218002)

### **1-13 BATTERY SPECIFICATIONS**

The battery provides standby power to the XL-AK memory.

Battery type: Lithium, 3.5 Volt  
Battery life: 15000 hours with power off.  
Shelf life 10 years when powered (or GPS-XL JP1 removed)

### **1-14 TIMING/FREQUENCY PERFORMANCE SPECIFICATIONS**

All performance specifications are valid when the antenna's geodetic position is known within 10 m in WGS-84 and four or more satellites are being tracked under the current conditions of Selective Availability (SA) as experienced at product release in March of 1994. **When operating with the standard TCXO as internal oscillator, all covers must be in place in order to meet the stated stability specifications.** During periods without SA, timing performance is improved to the +/- 100 nS level.

The GPS-XL core receiver specifications are:

Frequency: 1575.42 MHz (L1 signal).  
Code: Coarse Acquisition (C/A) code.  
Tracking: Up to six satellites.  
Acquisition Time: Less than 2 min. if satellites visible, position correct within 100 km. Position errors greater than 100 km may require 15 min. or longer, with satellites visible. See Section III.  
Single Fix Position Accuracy: Within 25 m (SEP) referred to WGS84 when sequentially tracking four (4) or more satellites with a PDOP  $\leq$  6. 100 meters (2 dRMS) if SA is enabled.  
24 Hour Averaged Position Accuracy: < 10 m

The XL-AK timing and frequency specifications are:

1PPS Output Accuracy: GPS Time +/- 150 nS  
UTC-USNO +/- 150 nS

Frequency Output Accuracy:  $< 3 \times 10^{-12}$

Frequency/Timing Stability: Allan Deviation,  
 $1 \times 10^{-9}$  @ 1 sec  
 $3 \times 10^{-10}$  @ 10 sec  
 $3 \times 10^{-10}$  @ 100 sec  
 $3 \times 10^{-12}$  @ 1 day

Oscillator Stability:  $2 \times 10^{-6}$ , over 0°C to 50°C when not tracking satellites.

IRIG-B Amplitude Modulated Output (STANDARD):

Accuracy: 10 uS to UTC

IRIG-B DC Level Shift Output (OPTION):

Accuracy: 150 nS to UTC, 100 nS without SA

Time Interval/Event Timing Input (OPTION):

Resolution: 30 nS, single shot.  
Accuracy: 150 nS + 30nS/2

Frequency Measurement Input (OPTION):

Resolution:  $6 \times 10^{-11}$  @ 1 second interval  
Accuracy:  $3 \times 10^{-12}$   
Stability: Same as Frequency & Timing Stability

**1-15 INTERFACE SPECIFICATIONS**

The standard serial data port is a bidirectional EIA standard RS-232C interface. RS-485 is available as an option. The specifications are:

Data: Time, day of year through milliseconds, in ASCII characters, output once per second or on request. Also special functions as listed in Section III.

Data Rates: User selectable on Model XL-AK-601 from 300, 600, 1200, 2400, 4800, 9600 and 19200 bps. Fixed on Model XL-AK-600 (user specified).

Data Bits: User selectable on Model XL-AK-601 from 7 or 8. Fixed on Model XL-AK-600 (user specified).

Parity: User selectable on Model XL-AK-601 from even, odd or none. Fixed on Model XL-AK-600 (user specified).

Stop Bits: User selectable on Model XL-AK-601 from 1 or 2. Fixed on Model XL-AK-600 (user specified).

Connector: Male 9-pin D subminiature.

Pin Assignment: See Section 1-60.

1-16 through 1-19 reserved

## **1-20 GPS-XL INPUTS AND OUTPUTS**

The Model XL-AK has two standard outputs that are provided by the GPS-XL assembly. These outputs are in addition to the five user configurable outputs available on the 86-690 "L" board (if installed) or the Low Phase Noise outputs from the 86-698 board (if installed). Refer to manual section V for details on the "L" board (if installed) signal specifications.

## **1-21 GPS-XL 1PPS OUTPUT (STANDARD)**

A time-stable ACMOS levels 50 ohm 1PPS output is connected to a rear panel BNC connector. The rising edge of this pulse coincides with the start of the second. The pulse width is 20 us. If no satellites are being tracked, the 1PPS pulse will be as stable as the internal (or external if so configured) oscillator of the XL-AK. The 1PPS output is capable of driving a 50 ohm load. This output is valid whenever the XL-AK has an accurate position and is tracking at least one satellite.

Pulse width: 20 uS  
On time edge: Rising  
Amplitude: TTL Levels into 50 ohms  
Drive: ACMOS

## **1-22 GPS-XL IRIG-B OUTPUT (STANDARD)**

An IRIG-B Amplitude Modulated 1KHz carrier output is connected to a rear panel BNC connector. The primary purpose of the IRIG-B time code output is to drive slave displays manufactured by TrueTime. Refer to Section VIII for a full description of this code. When using this code for other than driving the TrueTime Models RD-B, RMD-B, SF-DC or 560 Distribution Amplifier, it should be noted that four bits in the "control functions" portion of the IRIG-B code encode the TIME QUALITY INDICATORS. These are fully described in Manual Section VIII.

The modulated 1KHz sine wave is capable of driving a 600 ohm load. The high level of the code is 2.5 +/-0.25 volts peak-to-peak and the low level is .75 +/-0.1 volts peak-to-peak into 600 ohms. The open circuit levels are twice those into 600 ohms, i.e. the source impedance is 600 ohms.

Time Code: Amplitude-Modulated IRIG-B.  
Carrier: 1KHz.  
Amplitude: 5.0 Vp-p high, 1.5 Vp-p low, no load.  
Output Z: 600 ohms.

1-23 through 1-29 reserved

**GPS-XL OUTPUT OPTIONS:** (Refer to installed options checklist).

A combination of up to three optional GPS-XL Module input and output signals may be connected to the XL-AK via rear panel mounted BNC connectors.

### **1-30 GPS-XL TTL Time Code(s) IRIG-B, IRIG-E or IRIG-H (OPTION)**

An IRIG-B, IRIG-E or IRIG-H output(s) DC Level Shift Modulation output(s) are connected to rear panel BNC connector(s). Refer to Section VIII for a description of these codes. The DC level shift modulation output(s) provides TTL levels into 100 ohms or will drive up to 15 LSTTL loads.

Accuracy: 150 nS to UTC, 100 nS without SA  
Amplitude: TTL Levels into 100 ohms  
Drive: HCMOS

### **1-31 GPS-XL 1, 5, or 10 MPPS OUTPUT(s) (OPTION)**

Time-stable ACMOS levels 50 ohm 1, 5 or 10 MPPS outputs are connected to rear panel BNC connector(s). The duty cycles of the output waveforms are 50%. The rising edges of these signals coincide with the rising edge of the 1PPS output to within 100 nS.

Rate: 1 MPPS, 5 MPPS or 10 MPPS  
Waveform: Square Wave  
Amplitude: TTL Levels into 50 ohms  
Drive: ACMOS

### **1-32 GPS-XL 1, 5, or 10 MHz OUTPUT(s) (OPTION)**

Time-stable 1, 5 or 10 MHz sine wave output(s) are connected to rear panel BNC connector(s). The 1, 5 and 10 MHz outputs are driven by ACMOS and then LC filtered. The output(s) must be terminated with a 50 ohm load.

Rate: 1 MHz, 5 MHz or 10 MHz  
Waveform: Sine Wave  
Drive: 1 VRMS into 50 ohms

### **1-33 GPS-XL 1KPPS OUTPUT (OPTION)**

A time-stable ACMOS levels 50 ohm 1KPPS output is connected to a rear panel BNC connector. The duty cycle of this signal is 50%. The rising edge coincides with the rising edge of the 1PPS output.

Pulse width: 50% duty cycle

On time edge: Rising  
Amplitude: TTL Levels into 50 ohms  
Drive: AC MOS

### **1-34 GPS-XL SLOW CODE OUTPUT (OPTION)**

This output option is connected to a rear panel BNC connector. This output provides one pulse per minute, primarily for placing timing marks on drum recorders. Each pulse edge is aligned to within a few nanoseconds of the XL-AK's 1PPS output pulse, with the rising edge at the start of the minute.

The as shipped default values are:

Once per minute = 2 seconds  
Once per hour = 4 seconds  
Once per day = 6 seconds

Refer to Keypad and Serial Function 17 for detailed information on "SLOW CODE SETUP". The output is HCTTL levels and will drive up to 100 ohms or will drive up to 15 LSTTL loads.

Programmable  
Pulse Widths: On the Minute, On the Hour, On the Day (See Function 17)  
Drive: HCMOS  
Accuracy: 150 nS to UTC, 100 nS without SA

### **1-35 GPS-XL PRECISION 60PPS OUTPUT (OPTION)**

This output option is connected to a rear panel BNC connector. It is intended to be a frequency source for driving a synchronous motor through a power amplifier. This would allow a drum recorder to be kept synchronized to the correct time, independent of local power line frequency variations. The output is a quasi square wave with an unusual duty cycle. It is 50% over a period of 50 ms, or 3 cycles.

The cycle timings are:

cycle #1 high 9 ms, low 8 ms  
cycle #2 high 8 ms, low 9 ms  
cycle #3 high 8 ms, low 8 ms

The output is HCTTL levels and will drive up to 100 ohms or will drive up to 15 LSTTL loads.

Waveform: 50% over 50 ms, or 3 cycles  
Amplitude: TTL Levels  
Drive: HCMOS

### **1-36 GPS-XL ALARM OUTPUT-OPEN COLLECTOR (OPTION)**

The Alarm Output option is connected to a rear panel BNC connector. This output is controlled by Keypad or Serial Function 73 "REQUEST/SET ALARM STATUS/CONTROL". The open collector alarm output has the following states:

Off (High Z) Power off  
Off (High Z) Error, major or minor enabled alarm fault.



On (Low Z) Normal, no major or minor enabled alarm faults.

Drive: Open Collector  
Max. Voltage: 25 vdc  
Max. Current: 50 mA

### **1-37 GPS-XL PROGRAMMABLE PULSE OUTPUT (OPTION)**

This output option is connected to a rear panel BNC connector. It allows generation of a precisely synchronized trigger pulse at an arbitrary time and with arbitrary pulsewidth in integer multiples of 1 ms. The rising edge of the trigger output may be programmed to occur with 1 ms resolution and will be within 150 ns of the UTC millisecond. Refer to "SERIAL FUNCTION F26 - PROGRAMMABLE PULSE OUTPUT" for details on programming this output.

Pulse width: Programmable in mS steps (See Serial Function F26)  
On time edge: Rising  
Amplitude: TTL Levels into 100 ohms  
Drive: HCMOS

### **1-38 EXTERNAL OSCILLATOR CONTROL DAC OUTPUT (OPTION)**

This output option is connected to a rear panel BNC connector. This voltage output (DACOUT) in conjunction with the EXTERNAL OSCILLATOR INPUT (EXTOSC) option allows disciplining of an external oscillator directly via 16 bit DAC control. The user should specify the desired oscillator control voltage range -- either -5 to +5 VDC or 0 to +10 VDC (refer to 87-8XX configuration drawing JP5). The output impedance is 100 ohms. Refer to Keypad and Serial Functions 07 and 14 for configuring the XL-AK to support this option.

Range: Either -5 to +5 V or 0 to +10 V (user specified)  
Resolution: 16 bits  
Output Z: 100 ohms

1-39 through 1-49 reserved

**GPS-XL INPUT OPTIONS:** (Refer to installed options checklist)

### **1-50 EXTERNAL OSCILLATOR INPUT (OPTION)**

This input option is connected to a rear panel BNC connector. This input will accept an external lab standard oscillator as an alternate time base. This input (EXTOSC) in conjunction with the EXTERNAL OSCILLATOR CONTROL DAC output (DACOUT) option allows disciplining of an external oscillator.

When the XL-AK and External Oscillator are properly configured (refer to 87-8XX configuration drawing JP3, JP4, JP5 and JP6) and Keypad or Serial Functions 07 and 14 have been set correctly, and the External Oscillator Control DAC output is connected to the electronic frequency control input of the External Oscillator, the External Oscillator will be disciplined to the GPS system.

The input frequency for this input may be 1, 5, or 10 MHz. The signal may be TTL levels or a sine wave with an amplitude of 1.0 to 5.0 volts peak to peak. The user should specify the desired input impedance of either 1K or 50 ohms (set with 87-8XX jumper JP10 -- factory default = 50 ohms).

**CAUTION:** If the external oscillator is selected "ON" via Function 07 and **if no input is present** on the External Oscillator Input connector (EXTOSC), the operation of the unit will be unpredictable. The jumper settings **MUST** match the mode set by Function 07.

Frequency: 1, 5 or 10 MHz  
Level: 1 to 5 Vpp  
Impedance: 1K or 50 ohms (user specified)

### **1-51 TIME INTERVAL/EVENT TIMING INPUT (OPTION)**

This input option is connected to a rear panel BNC connector. This input will accept an externally applied 1PPS or Event input signal for measurement against the GPS derived UTC time. The signal may have a minimum pulse width of 100 nS. It must have a TTL low level and its high level must be in the range from a TTL high level to 10 VDC. The input impedance is selectable at 1K or 50 ohms and should be user specified (refer to 87-8XX configuration drawing JP7 -- factory default = 50 ohms). The rising edge of the pulse is measured with respect to the XL-AK time to 30 nS. Refer to Keypad or Serial Function F28 for details concerning the use of this input.

Pulse width: 100 ns, min.  
Active Edge: Rising  
High Level: TTL to 10 VDC  
Low Level: TTL  
Hysteresis: 50 mV  
Impedance: 1K or 50 ohms (user specified)  
Resolution: 30 nS, single shot  
Accuracy: 150 nS + 30 nS/2

### **1-52 FREQUENCY MEASUREMENT INPUT (OPTION)**

This input option is connected to a rear panel BNC connector. This input will accept an externally applied signal for measurement with respect to the XL-AK disciplined frequency. The input frequency may be 1, 5, or 10 MHz. The resolution of the measurements is  $6 \times 10^{-11}$  at 1 second averaging. The input signal may be TTL levels or a sine wave with an amplitude of 1.0 to 5.0 volts peak to peak. The input impedance is selectable at 1K or 50 ohms (refer to 87-8XX configuration drawing JP9 -- factory default = 50 ohms) Refer to Keypad or Serial Function 29 for details concerning the use of this input.

Resolution: 6 x 10E-11@ 1 second interval  
 Accuracy: 3 x 10-12  
 Stability: Same as Frequency & Timing Stability  
 Impedance: 1K or 50 ohms (user specified)  
 Frequency: 1, 5 or 10MHz

1-53 through 1-59 reserved

**1-60 SERIAL INTERFACE**

The SERIAL port can be connected to a terminal or computer. These instructions assume that a terminal is connected. The SERIAL connection and data format are explained in the following sections. The Serial functions are explained in manual Section III.

**1-61 RS-232/RS-485 CONNECTION**

A male 9-pin D connector (DB-9P) provides a serial, asynchronous, bi-directional data port. This Serial data port is factory configured with either RS-232 (STANDARD) or RS-485 (OPTION) signal levels. The RS-232 output is compatible electrically and mechanically with the EIA Standard RS-232C as described for **data terminal equipment (DTE)**. A copy of the RS-232 Standard is available from Electronic Industries Association, Engineering Department, 2001 Eye Street, N.W., Washington, D.C. 20006. This reference is suggested for any user of this system as it is the industry accepted standard for this interface system.

Messages are sent and received using ASCII coded characters in most standard data rates and formats. The mating D connector for P4 is a female 9-pin (DB-9S). If a 9 to 25 pin adapter cable is used, the Serial port pin assignments are as follows:

9-PIN to 25-PIN ADAPTER CABLE		SIGNAL DESCRIPTION
DB-9P	DB-25P	
1.....	8	
2-----<	3	RxD, RECEIVED DATA
3----->	2	TxD, TRANSMITTED DATA
4.....	20	
5-----<>	7	SIGNAL GROUND
6.....	6	
7.....	4	
8.....	5	
9.....	22	

When configured for RS-485 operation, the connections are:

9-PIN to 25-PIN ADAPTER CABLE		SIGNAL DESCRIPTION
DB-9P	DB-25P	
1-----<-----	8	RxD-, RECEIVED DATA
2-----<-----	3	RxD+, RECEIVED DATA
3----->-----	2	TxD+, TRANSMITTED DATA
4----->-----	20	TxD-, TRANSMITTED DATA
5-----<>-----	7	SIGNAL GROUND
6.....	6	
7.....	4	
8.....	5	
9.....	22	

### **1-62 SERIAL DATA FORMAT**

The default Serial format, as shipped, is:

Data Rate:	9600 bits/second
Word Length:	7 bits
Parity:	Even
Stop Bits:	1

The format cannot be changed via the Serial port. Factory or Keypad (see "KEYPAD FUNCTION 04 - SERIAL PORT SETUP") configured formats available are:

Baud Rates:	300, 600, 1200, 2400, 4800, 9600, 19200
Word Lengths:	7 or 8 bits
Parity:	Even, odd or none
Stop Bits:	1 or 2

### **1-63 EXCLUSIVE USE**

To facilitate remote operation, the unit has the ability to grant "exclusive use" (see Serial function F15) to the Serial port. The front panel keypad cannot be granted exclusive use. The Serial port can have exclusive use until sent a command to release it or until the unit loses power. At power-on or when exclusive use is off the Serial port or the front panel keypad has free access. When the Serial port has exclusive use the front panel keypad cannot change any of the setup parameters. The keypad can, however, request the current parameters.

Example:

If the Serial port has exclusive use and "FUNC/ENTR" "0" "1" is pressed on the keypad, the current time zone will be displayed. If "FUNC/ENTER" is pressed, attempting to set the time zone, an error message displays and the time zone displays again. To exit the function use the "TIME", "STATUS", or "POSITION" button.

## SECTION II

### INSTALLATION

#### **2-1 OVERVIEW**

The Model XL-AK Time and Frequency receiver consists of the XL-AK receiver, Antenna unit and cable. The XL-AK is capable of basic operation without any RS-232 connection. Since the standard internal oscillator is a Temperature Compensated Crystal Oscillator (TCXO), it is essential that it be isolated from rapid fluctuations in air temperature. For this reason, *operation with all covers in place is required in order to obtain specified stability performance levels.* When an optional higher stability ovenized oscillator is used in the XL-AK, this is not necessary.

#### **2-2 PROCEDURE**

Place the XL-AK Antenna unit with an unobstructed view of the sky. Connect the cable between the Antenna unit and XL-AK antenna input connector. If Serial I/O communications are desired, make the necessary connections to your equipment after referring to the Serial Interface information in manual Section I. The XL-AK-601 will also have display and keypad functionality. These are thoroughly described in manual Section III.

The receiver can be powered by 95-260 VAC or 120-370 VDC. See Section I for specific limits on the voltage and frequency ranges.

NOTE: The rear panel IEC power receptacle is used for both AC and the Optional High Voltage DC inputs, and is insensitive to polarity.

The power fuse for the AC or DC power input is integral to the internal power supply. Replace with TrueTime part number 363-2.0SB (Littelfuse # 218002).

Connect an appropriate AC or Optional DC power source to the XL-AK receiver via the IEC power connector. Within a few seconds, the XL-AK will output elapsed time from power-on via Serial function F08. (Serial inputs will be ignored until the F08 output is terminated with a CTRL-C character (Hex 03).) If satellites are visible, the output time will switch from elapsed time to UTC time within a few minutes.

If the XL-AK has been placed in AUTO mode via Function 53, the recommended setting for new installations, it will not phase lock its internal oscillator to the received time signal until it has computed a 3-D position. You may wait up to 15 minutes for the XL-AK to independently ascertain its position by acquiring four satellites, or you may speed up the process by using Function 50 to enter the approximate location to an accuracy of 1° (about 100 km) or better.

When the XL-AK has phase locked its oscillator to the GPS signals and has set its 1PPS output to the specified accuracy, the terminating character of the Serial function F08 continuous time output string will change from a "?" to a "space" at this time. If satellites are visible and the XL-AK has an accurate position, lock should be achieved within three minutes. XL-AK units with optional internal or external ovenized oscillators will require a longer time to lock due to the oscillator warm-up time.

Initially following power-up, the optional open collector alarm output will provide a high impedance to ground. When the XL-AK is tracking satellites and is controlling the local oscillator and 1PPS output to within specified accuracy to UTC, this output will provide a low impedance to ground. Thereafter,

whenever the XL-AK outputs are not within specifications, this output will provide a high impedance to ground.

### **2-3 SPECIAL CONSIDERATIONS FOR EXTERNAL OSCILLATOR CONTROL OPTION**

Interconnection between the XL-AK and the external oscillator to be controlled must be planned carefully. Of particular importance is the elimination of ground loops made by the connection of power supply returns, DAC control voltage return and the signal ground shield. Some types of oscillators are particularly susceptible to noise in these loops which can cause missing pulses to occur at the XL-AK External Oscillator input signal conditioning circuits.

The recommended connection method is as follows:

- 1) Provide a single ground path between the XL-AK and the External Oscillator.
- 2) Let that single ground provide the DAC tuning voltage return.
- 3) Transformer couple the External Oscillator signal into the XL-AK to break the coaxial ground connection, thereby eliminating that potential ground loop.

Following these guidelines will provide reliable operation with a wide variety of oscillators.

### **2-4 RACK MOUNTING**

The XL-AK mounts in a standard 19 inch rack system using the rack mounting brackets provided. These brackets may be attached to the sides of the cabinet. First remove the screws from each side of the instrument. Place the screws supplied with the brackets through the countersunk holes in the brackets then into the clock and tighten. The unit may now be mounted in a 1-3/4 inch opening in any EIA Standard 19 inch rack system.

## SECTION III

### OPERATION

#### **3-1 INTRODUCTION**

The Model XL-AK Time and Frequency Receiver provides extremely accurate TIME and FREQUENCY that is traceable to the UNITED STATES NAVAL OBSERVATORY (USNO) by use of the NAVSTAR Global Positioning System (GPS). This section provides a complete description of the operation of the XL-AK. For the Model XL-AK-600, all references to the front-panel keypad and alphanumeric display should be ignored as they are only available on the Model XL-AK-601. NOTE: Assembly and/or schematic drawings that may be included in this manual will be identified as 600-100 for the XL-AK-600 units and as 600-101 for the XL-AK-601 units. *Only Maintenance manuals will include schematic drawings.*

#### **3-2 GENERAL OPERATION**

Every effort has been made to make the operation of the XL-AK backwardly compatible with the Keypad and Serial functionality of the GPS-DC and GPS-TMS/TMD products, however some differences exist. The three most-used functions (TIME, STATUS and POSITION) have been assigned to front-panel push buttons. All remaining functions may be accessed via the front-panel keypad and viewed on a front-panel alphanumeric display or accessed via the Serial port interface and viewed on a monitor. The XL-AK is completely compatible with the Keypad and Serial functionality of the XL-DC product.

#### **3-3 XL-AK START-UP**

At power up, the unit will present messages on the front panel LCD display to indicate the version of software installed in the unit, and how to invoke the keypad help function. The first message is the version of the system software. For example:

```
TRUETIME Mk III  
sys ver 020
```

After a few seconds, the display will show:

```
Press func, 0, 0  
for help.
```

Then the display will show the version of the clock-specific software:

```
GPS-XL V1.036  
182-6064v004
```

After a few seconds, the display will show the status display, which will remain until a keypad function is invoked, or the "TIME" or "POSITION" button is pressed.

It should be noted that the text of the version messages will vary from model to model and version to version.

After power up, the XL-AK will send over the Serial port continuous time with a one second update rate. The format of this output string is described in section 3-208, "SERIAL FUNCTION 08 - CONTINUOUS TIME ONCE PER SECOND ENABLE". Prior to satellite acquisition the time either displayed or sent over the Serial port is battery-backed GPS time. Once satellite signals are acquired, UTC time is displayed.

Similarly, time is send to the Serial port with local offset and the "?" time quality character will clear to a space character. Sending a CTRL-C (Hex 03) to the XL-AK Serial port will terminate this continuous time output mode and allow requesting of other information via the Serial function commands.

The Model XL-AK includes a Red/Green LED on the front panel that provides Status information. Detailed function of the Status LED is described in manual sections 3-173 and 3-273 "REQUEST/SET ALARM STATUS/CONTROL". Factory defaults for function 73 produce an ORANGE Status indication at power up, and a blinking at 1 pulse per second GREEN Status indication after the unit locks.

### **3-4 SATELLITE ACQUISITION**

Time to first satellite acquisition is dependent upon many factors. The following paragraphs describe some of the possible events which affect satellite acquisition times. Note that satellite visibility at the receiver site will affect acquisition times.

If the Time and Frequency receiver was tracking satellites immediately prior to a momentary power interruption, satellite reacquisition will be almost immediate with valid UTC time available within 180 seconds.

If the current position is unknown or in error by more than 100 km, acquisition typically requires from 3 to 15 additional minutes to locate current antenna position, re-acquire satellite almanac and ephemeris data, and deliver UTC time. Refer to the AUTO MODE paragraph later in this section for operational details.

If internal battery-backed time and/or almanac data is lost, the time to first satellite acquisition will depend upon which satellites are visible at the time of power-on. The XL-AK will attempt to acquire satellites not knowing which satellites are visible. The satellite search will be expanded until a satellite is acquired. After first satellite acquisition, time will be acquired from the satellite and the receiver will return to normal operation. This procedure may take as little as 3 minutes to as long as 15 minutes depending upon current satellite visibility.

To verify the status of the Model XL-AK-601 receiver, a front panel "STATUS" button has been provided. Refer to "STATUS PUSH BUTTON" in this section.

3-5 through 3-9 reserved



### **3-10 OPERATIONAL MODES**

The XL-AK operates under one of three modes: AUTO, SURVEY and TIME. Each mode is described below. Use Keypad or Serial function 53 to change from one mode to another or to determine the current mode. Refer to "KEYPAD FUNCTION 53 - OPERATIONAL MODE ENTRY/REQUEST" or "SERIAL FUNCTION F53 - OPERATIONAL MODE ENTRY/REQUEST" in this section. The as shipped default mode is AUTO. The default on subsequent power-up will be the mode used at the previous power-down.

### **3-11 AUTO MODE**

AUTO mode offers a painless solution to GPS receiver start-up and operation. Under AUTO mode, no user input is required to properly complete a XL-AK site installation.

AUTO mode requires a minimum of 4 satellites in order to complete the installation process.

After XL-AK receiver installation or whenever it is desired to reinstall the XL-AK, select AUTO MODE to begin the installation process.

AUTO mode consists of 3 major processes: 1) Current Position Search, 2) Current Position Averaging and Refinement; and 3) Invocation of Time Mode. Time and Frequency data and output signals are available throughout this process, however optimal accuracy and stability are not achieved until step 2) has been completed. With good satellite visibility this occurs following about twenty-four hours of averaging.

Current Position Search: Immediately after invoking AUTO mode, the XL-AK clears the position average and the GPS core receiver Non-Volatile Random Access Memory (NVRAM) and then begins a satellite search. **Since invocation of AUTO mode does clear the average position, the time and frequency outputs may be disturbed. Care should be taken not to needlessly invoke the AUTO mode.**

The satellite search begins with 8 satellites. After several minutes, a second set of satellites is searched. The process continues until a satellite is acquired.

Immediately after acquisition, data lock is attempted and the satellite doppler compensation (the change in the 1.575 GHz frequency due to the apparent satellite velocity, for terrestrial based receivers, typically 0 to  $\pm 5$  KHz) is adjusted until data can be read from the satellite.

After data lock, GPS time is acquired to the 20 mS level of accuracy, and almanac data loading for the entire constellation begins. At this time the Serial function F53 command returns "F53 AUTO: 1 SATS" and the first line of the display indicates "MODE: AUTO 1 SAT", giving the positioning mode of the GPS core unit. The second line indicates "sats ##", giving the Pseudo Random Noise (PRN) number of the satellite being tracked.

During the data loading process, additional satellites are searched. When a second satellite is acquired and data lock is achieved, the Serial function F53 command returns "F53 AUTO: 2 SATS" and the first line of the display indicates "MODE: AUTO 1 SAT", giving the positioning mode of the GPS core unit. The second line indicates "sats ##", giving the PRN number of the highest satellite being tracked. At this time, the position of the XL-AK may be placed in the proper hemisphere, narrowing the search for possible SV's.

When a third satellite is acquired, a unique position solution exists given an assumed ellipsoid height near 0 meters. At this time, the Serial function F53 command returns "F53 AUTO: 3 SATS" and the first line of the display indicates "MODE: AUTO 2-D", giving the positioning mode of the GPS core unit. The second line indicates "sats ## ## ##", giving the PRN numbers of the three satellites being used in the two-dimensional (2-D) fix. With this position, the remaining visible SV's are determined based on the almanac and the time and are acquired rapidly. Once a 3-D position fix has been determined, synchronization to UTC begins and the first stage of AUTO Mode has almost ended. At this time the Serial function F53 command returns "F53 AUTO: # SATS", where # is the number of SV's being tracked, which may be as many as 6. The first line of the display indicates "MODE: AUTO 3-D" while the second line indicates "## ## ## ## ## ##", giving the PRN numbers for up to six satellites being tracked.

During the position refinement stage of AUTO mode, the constellation may change such that 3-D fixes are not available. This will be indicated on the status display. *Though these 0-D and 2-D fixes will not go into the position average, they will be used to control the time and frequency outputs of the XL-AK.*

Current Position Averaging and Refinement: After completing the first Current Position Search phase of AUTO mode, AUTO mode automatically begins averaging position fixes, providing an increasingly more accurate and stable time and frequency reference position. The quality of the timing and frequency outputs will improve until a terminal average of approximately twenty-four hours duration has been obtained. At this time, the XL-AK returns "F53 TIME: # SATS" in response to the Serial function F53 command and the first line of the display indicates "MODE: TIME X-D", where X is either 2 or 3 depending upon the satellite visibility. As in AUTO mode, the second line of the display indicates the PRN numbers of the current satellites being used in the TIME solutions.

Invocation of TIME Mode: After the position average is complete, the AUTO mode switches the XL-AK to TIME mode and the averaged position will be used for all future timing solutions. TIME mode inhibits further surveying. The auto installation process is concluded.

The XL-AK will remain in TIME mode and will power-up in TIME mode using the averaged position after a power outage. However, after powering up in TIME mode, if the computed positions consistently differ from the previously stored average position by more than 1 km for a significant period of time, the XL-AK will automatically invoke AUTO mode to re-establish the position. Otherwise, operator intervention would be necessary to re-invoke AUTO mode.

### **3-12 SURVEY MODE**

When in the SURVEY operational mode, the XL-AK will repeatedly calculate position and time based on the unaveraged position. The position solutions are not averaged, and multiple satellite averaging techniques for reducing the effects of SA on the time solution are not employed. This mode of operation is appropriate in dynamic or pseudo-static platform applications. Strictly stationary users should use the far more accurate and stable TIME mode. **The specified time and frequency performance levels may not be met when the XL-AK is operating in SURVEY mode.**

There are two choices for SURVEY operation: STATIC and DYNAMIC. STATIC should be used when the mode of operation is pseudo-static, i.e. the unit is periodically transported to a new location and then stationary operation is performed at the new location. In this mode, the GPS core receiver will easily maintain lock under the dynamics experienced during ground transport and will quickly provide accurate time and frequency once at the new site. This mode also supports operation with a single satellite once the position at the new site has been determined. However, if operation while moving is important and the possibility of satellite obstruction exists, STATIC should not be selected as erroneous time and frequency steering data could be used while only a single satellite is visible.

DYNAMIC should be selected when operation is truly dynamic and might possibly include high acceleration or velocity such as might be experienced on-board tactical aircraft. In this mode, satellite visibility must be complete and fall-back to single satellite operation is not supported.

### **3-13 TIME MODE**

When in the TIME operational mode, the XL-AK disables updating of the reference position average and computes timing solutions based on either the previously averaged position or a reference position which has been input via either Keypad or Serial function 56. However, each position fix update is tested against the reference position to detect possible relocation of the receiver and antenna during the last power off period. If the XL-AK determines that it has been moved by more than 1 km, it will automatically set itself into the AUTO mode of operation.

Up to six satellites are used for timing solutions, enabling significant reduction of the effects of Selective Availability on the stability and accuracy of the timing and frequency outputs and measurement data. These satellites are chosen to be the highest ones currently available.

3-14 through 3-19 reserved

### **3-20 TIME QUALITY INDICATION**

Whenever the XL-AK is not tracking satellites, the timing accuracy will be dependent upon the accuracy and stability of the currently selected oscillator (internal or external). Time error accumulates depending upon the stability of the oscillator used and the accuracy to which it was set prior to loss of GPS steering information. The XL-AK continually calculates an estimate of the "worst-case time error". When the receiver is tracking satellite signals and is operating from a known position, the worst-case error is 200 ns. If lock with all satellite signals is lost, the Serial function F53 command returns "F53 MODE: 0 SATS", where "MODE" is the current operating mode, i.e. AUTO, SURVEY, TIME. If the time quality indicator character is enabled (see SERIAL FUNCTION 11 - OUTPUT FORMAT ENTRY/REQUEST) then the time string returned by either Serial function F08 or F09 will indicate the worst-case time error with a different character for each of four thresholds. The user may enable, disable and set these thresholds using Serial function F05. As shipped these indicators are enabled and the default thresholds are:

First threshold	- 1 us
Second threshold	- 10 us
Third threshold	- 100 us
Fourth threshold	- 1000 us

New threshold values entered are retained upon power-down and are the new defaults upon subsequent power-ups.

### **3-21 FRONT PANEL INTERFACE**

The primary user interface on Model XL-AK-600 is the Serial port (refer to Serial functions). On Model XL-AK-601, the front panel is the primary user interface. Input is via three front panel push buttons and a 16-key keypad, output is via a two line 32-character alphanumeric display that provides status and various function information.

3-22 reserved

### **3-23 ALPHANUMERIC DISPLAY**

The alphanumeric display is used both to display current clock status and as a means of communicating information accessible through the XL-AK list of keypad functions.

When not being used for keypad function operation, the alphanumeric display can be set to display the current clock mode and satellite tracking status or the current time with calendar day and year. Current position information is also available but, because it requires several screens to display all of the position information, current position information is only updated upon subsequent requests.

### **3-24 TIME PUSH BUTTON**

Pressing the TIME push button places the time-of-year and the date on the alphanumeric display. The format of the date is day-of-week, month, day-of-month, year.

### **3-25 STATUS PUSH BUTTON**

The Status Push Button is used to place current clock status on the alphanumeric display.

Additionally, PRESSING THE STATUS BUTTON WILL ABORT ANY KEYPAD FUNCTION CURRENTLY IN PROGRESS. If an incorrect function was entered, or if the alphanumeric display shows something unexpected, pressing the status push button will abort the function with no action taken by the function.

When pressed, the Status Push Button places the current clock mode and satellite tracking status on the alphanumeric display.

If the clock is not tracking satellites, the display will show:

STATUS: looking  
for Satellites

If the clock has acquired a satellite but has not yet acquired satellite data lock, the display will show:

STATUS: No usable  
satellites yet

If the clock has achieved satellite data lock, then the display will show "STATUS:", the current mode ("AUTO", "SURVEY", or "TIME"), the position fix mode ("1 sat", "2-D", or "3-D"), and up to six Pseudo Random Noise (PRN) number(s) of the satellite(s) being tracked.

### **3-26 POSITION PUSH BUTTON**

Pressing the POSITION button will cause the location of the antenna to be displayed. The first time the POSITION button is pressed the alphanumeric display will show:

LATITUDE N 38 23'55.0"

There may be a delay of several seconds before the latitude appears. This delay is necessary to obtain the current position solution from the core GPS receiver module.

The second time the POSITION button is pressed the display will show:

LONGITUDE W 122 42'56.0"

The third time the POSITION button is pressed, the display will show:

Altitude	or	Altitude
+000050 Meters		+000152 Feet

The fourth time the POSITION button is pressed, the display will show:

Pdop  
+2.06

which is the position dilution of precision (PDOP).

Each press of the POSITION button will cause the display to scroll through these four readings. The position that is displayed will change slightly each time it is displayed if the unit has adequate satellite visibility. Since these positions are unaveraged single fixes their accuracy is limited by both the geometry of the satellite constellation and the effects of SA. The fixes displayed using this button are equivalent to those returned via either keypad function 50 or Serial function F50.

### **3-27 KEYPAD OPERATION**

The 16-key panel-mounted keypad consists of numeric keys "0" through "9", arrow keys "up", "down", "right", and "left", a clear key "CLR" and the function/enter key "FUNC/ENTR". Refer to "SELECTING FUNCTIONS AND ENTERING DATA" in this section before attempting function entries. The following rules are for keypad function entry:

- A. STATUS, TIME, or POSITION should be on the alphanumeric display before starting a function. If not, press the "STATUS" button.
- B. It takes several seconds for some functions to appear. If nothing happens after several seconds, press "STATUS", then try again.
- C. When pressing keypad buttons, hold the button for 1/4 second to reduce contact bounce and insure the key is recognized. Short "pokes" may result in bad entries.
- D. To enter a specific function first press FUNC/ENTR then the function number. Be sure to include the leading zeros for functions less than ten. If the function number is currently

unassigned or not implemented the alphanumeric display will show the "Function not implemented" message and will then revert to STATUS.

- E. When entries are complete and the display shows the desired data, press "FUNC/ENTR".
- F. The "CLR" key will clear data entered. Example: If you intended to enter a value of 865, but notice just prior to pressing the "FUNC/ENTR" that you inadvertently entered 855, press "CLR". The display will revert to the previous value. Re-enter 865 and press "FUNC/ENTR". To verify your entry, press "FUNC/ENTR" and the appropriate function number and the data will display. To leave this function unchanged simply press the "STATUS" button. Your entry will remain unchanged and the display will have reverted back to "STATUS".
- G. Use the left or right arrow keys to move the cursor beneath the character that you wish to edit. Use the up or down arrow keys to scroll through the possible choices for that character.

### **3-28 SELECTING FUNCTIONS AND ENTERING DATA**

The various keypad functions are listed in the following KEYPAD FUNCTION LIST. Some of these functions are optional and may not be included in your unit. If in doubt as to whether your unit includes a particular function, try it. The alphanumeric display shows the message "Function not implemented" if the function is not in your firmware. NOTE: Most of the functions must be requested to obtain the most current value.

3-29 through 3-98 reserved

### **3-99 KEYPAD FUNCTION LIST**

<b>FUNCTION</b>	<b>DESCRIPTION</b>	<b>AS SHIPPED</b>	<b>POWER-UP DEFAULT</b>
00	Keypad Help Function	--	--
01	Time Zone Entry/Request	00	Last Entry
02	12/24 Hour Format Entry/Select	24	Last Entry
03	Time/Date Entry/Request	--	--
04	Serial Port Setup	9600,7,1,even	Last Entry
05	Time Quality Enable/Setup	On	Last Entry
06	Keypad Lockout Enable	Off	Last Entry
07**	External Oscillator Enable	Off	Last Entry
13	Worst-case Time Error Request	--	--
14**	Ext Osc Parameter Entry/Request	--	Last Entry
16	Emulation Mode Enable	Off	Last Entry
17**	Slow Code Setup	2,4,6 sec.	Last Entry
18	Software Version Request	--	--
28**	Time Interval/Event Timing Input	Off	Off
29**	Frequency Measurement Input	Off	Off
31***	Backlight Enable	On	Last Entry
50*	Position Entry/Req.	Santa Rosa, CA	Last Calc.
51	Antenna Cable Delay Entry/Request	60 ns	Last Entry
52	Distribution Cable Delay Entry/Request	0 ns	Last Entry
53	Operational Mode Entry/Request	AUTO	Last Entry
55	Altitude Units Entry/Request	Meters	Last Entry
56	Average Position Entry/Request	N 00d00'0.0" E 000d00'0.0"	Last Entry
60	Satellite List Request	--	--
65*	Satellite Select	All	Last Entry
66	Daylight Saving Enable	Off	Last Entry
68	Year Entry (GPS Epoch Management)	--	Last Entry
69	Select Local/Standard/GPS/UTC Time	UTC	Last Entry
71	Oscillator Statistics Request	--	Last Calc.
72	Fault Status Request	--	--
73	Request/Set Alarm Status/Control	(See Keypad Function 73)	
79	Warm Start		

\* Allow 10 seconds after entering data.

\*\* Optional Function

\*\*\* Special Order Option

### **3-100 KEYPAD FUNCTION 00 - KEYPAD HELP FUNCTION**

Use keypad function 00 to obtain a short description of all keypad functions available.

Press "FUNC ENTR", then "0" "0". The display will show:

up, down keys  
to view list

Press any key to see the next display:

Func/enter key  
to call function

Press any key to see the next display, the first entry in the keypad function description list:

f01: Sets time  
zone

The list of available keypad functions can be viewed by pressing the up or down arrow keys. Each entry in the list gives the function number and a short description of the function's purpose. If the "FUNC/ENTR" is pressed, the function being displayed will be invoked. When a function so invoked is finished, the display will revert to "status".

The help function can be exited without invoking a function by pressing the "TIME", "STATUS", or "POSITION" buttons.

### **3-101 KEYPAD FUNCTION 01 - TIME ZONE ENTRY/REQUEST**

Use function 01 to enter the time-zone offset. The as shipped default is 00:00 (UTC). The default on power-ups will be the value used before power-down. The Time Zone range is +12:00 to -12:00 hours.

Press "FUNC/ENTR", then "0" "1". The display will show:

Time zone hr:min  
±00:00

Press the right or left arrow keys to position the cursor beneath the character that you wish to change. Press the up or down arrow keys to scroll through the possible choices. Alternately, directly enter the numbers using the keypad. When the display shows the desired time-zone offset press "FUNC/ENTR" to enter your choice.

### **3-102 KEYPAD FUNCTION 02 - 12/24 HOUR FORMAT ENTRY/REQUEST**

Use function 02 to select either the 12-hr or 24-hr time display format. The as shipped default is the 24-hr format. The power-up default will be whatever the format was before power-down.

Press "FUNC/ENTR", then "0" "2". The display will show:

12/24 hr Format or 12/24 hr Format  
24                      12

Press the up or down arrow keys to toggle between 24 and 12. When the display shows the desired format, press "FUNC/ENTR" to enter your choice.



### **3-103 KEYPAD FUNCTION 03 - TIME/DATE ENTRY/REQUEST**

Use function 03 to enter or request time and date.

Press "FUNC/ENTR", then "0" "3". The display will show:

Date-time	or	Date-time
<u>U</u> TC		<u>L</u> ocal

Press the up or down arrow keys to toggle between "UTC" and "Local" depending on which you intend to enter. When the display shows your choice, press "FUNC/ENTR" again and the display will show:

Date-time  
MM/DD/YY

where MM is the month, DD is the day and YY is the year. Press the right or left arrow keys to move the cursor beneath the digit that you wish to change. Press the up or down arrow keys to scroll through the possible choices. Alternately, directly enter the numbers using the keypad. The cursor will advance to the next digit automatically. NOTE: Although an illegal entry will display, the entry will not be accepted.

Press "FUNC/ENTR" again and the display will show:

Date-time  
HH:MM:SS

where HH is the hours, MM is the minutes and SS is the seconds.

Press the left or right arrow keys to position the cursor beneath the digit that you wish to change. Press the up or down arrow keys to scroll through the possible choices. Alternately, directly enter the numbers using the keypad. The cursor will advance to the next digit automatically. Press "FUNC/ENTR" to enter the data. NOTE: Only valid times will be accepted.

### **3-104 KEYPAD FUNCTION 04 - SERIAL PORT SETUP**

Use function 04 to configure the Serial port. The as shipped default values are:

Baud Rate	9600
Data Bits	7
Parity	even
Stop bits	1

The default values on power-ups will be those in use prior to power-down.

Press "FUNC/ENTR", then "0" "4". The display will show:

Ser port setup  
Baud rate 9600

Press the up or down arrow keys to scroll through the possible baud rate choices. When the display shows the desired baud rate, press "FUNC/ENTR" again and the display will show:

Ser port setup  
Data bits 7

Press the up or down arrow keys to toggle between 7 and 8 data bits choices. When the display shows the desired choice, press "FUNC/ENTR" again and the display will show:

Ser port setup  
Parity even

Press the up or down arrow keys to toggle between even or odd parity. When the display shows the desired parity press "FUNC/ENTR" again and the display will show:

Ser port setup  
Stop bits 1

Press the up or down arrow keys to toggle between 1 and 2 stop bits. When the display shows the desired choice, press "FUNC/ENTR" to enter all Serial port parameters.

### **3-105 KEYPAD FUNCTION 05 - TIME QUALITY ENABLE/SETUP**

Both the front-panel numeric display and the Serial port time output string indicate time quality. Refer to NUMERIC DISPLAY earlier in this section for a complete description of the display's time quality indications. Refer to Serial FUNCTION FO8 - CONTINUOUS TIME ONCE PER SECOND for a description of the time quality indication in the Serial port time output string. As shipped, time quality indication is enabled and the thresholds are:

First threshold	-	1 uS
Second threshold	-	10 uS
Third threshold	-	100 uS
Fourth threshold	-	1000 uS

The acceptable threshold values are 00000000200 nS to 40000000000 nS.

Use Function 05 to enable or disable the time quality indication or set the worst-case-error thresholds. Press "FUNC/ENTR", then "0" "5". The display will show:

Time quality      or      Time quality  
on                                      off

Press the up or down arrow keys to toggle between "on" and "off". When the display shows the desired state, press "FUNC/ENTR". The display will show:

First tq flag:  
00000000000ns

or the current value. Press the right or left arrow keys to position the cursor beneath the digit that you want to change. Press the up or down arrow keys to scroll through the possible digit choices. Alternately, directly enter the numbers using the keypad. The cursor will advance to the next digit

automatically. When the display shows the desired value for the first time quality threshold, press "FUNC/ENTR" and the display will show:

Second tq flag:  
00000000000ns

or the current value. Using the same combination of arrow keys and direct digit entry, when the display shows the desired value for the second time quality threshold, press "FUNC/ENTR" and the display will show:

Third tq flag:  
00000000000ns

or the current value. Using the same combination of arrow keys and direct digit entry, when the display shows the desired value for the third time quality threshold, press "FUNC/ENTR" and the display will show:

Fourth tq flag:  
00000000000ns

or the current value. Using the same combination of arrow keys and direct digit entry, when the display shows the desired value for the fourth time quality threshold, press "FUNC/ENTR" and all of the time quality thresholds will be stored.

### **3-106 KEYPAD FUNCTION 06 - KEYPAD LOCKOUT ENABLE**

Use function 06 to enable or disable the keypad. The keypad lock function, when enabled, prevents unauthorized or accidental entries on the keypad. The as shipped default is "off". The default upon subsequent power-ups will be the same as it was on the previous power-down.

Press "FUNC/ENTR" then "0" "6". The display will show:

Keypad Lock    or    Keypad Lock  
on                      off

Press up or down arrow keys to toggle between "on" and "off". When the display shows the desired choice, press "FUNC/ENTR". After the keypad lock is enabled, any attempt to enter a function on the keypad (except keypad function 06) will result in the message "Keypad locked" or "Function not implemented".

### **3-107 KEYPAD FUNCTION 07 - EXTERNAL OSCILLATOR ENABLE (OPTION)**

Use function 07 in conjunction with function 14 to enable or disable Phase Locking to an External Oscillator. The hardware configuration of the XL-AK must be able to support this function. The as shipped default is "on". The default on power-up will be the same as it was on power-down.

Press "FUNC/ENTR" then "0" "7". The display will show:

Ext Oscillator    or    Ext Oscillator  
DISabled            ENabled

Press the up or down arrow keys to toggle between "Disabled" and "Enabled". When the display shows the desired choice, press "FUNC/ENTR" to enter your choice.

3-108 through 3-112 reserved

### **3-113 KEYPAD FUNCTION 13 - WORST-CASE TIME ERROR REQUEST**

Use function 13 to display the worst-case time error due to oscillator drift during periods when satellites are not being tracked.

Press "FUNC/ENTR", then "1" "3". The display will show:

Time error  
Over range

if the unit has not yet acquired valid time or:

Time error  $\pm$   
00.000 000 200

if the unit is tracking satellites and has acquired valid time.

If the XL-AK acquired valid time but subsequently lost lock to the satellite signals, the time output will begin to drift. This drift is dependent on the stability of the internal or the optional external oscillator and the accuracy to which it had been set on frequency prior to the outage. The stability of the optional external oscillator must be entered using Keypad or Serial function 14. The processor calculates and displays in seconds the worst-case time based on the stability of the oscillator in use.

### **3-114 KEYPAD FUNCTION 14 - EXTERNAL OSCILLATOR PARAMETER ENTRY/REQUEST (OPTION)**

If the external oscillator is enabled (function 07), the parameters of the external oscillator are used to calculate the control coefficients as well as the worst-case time error as described by function 13. Use Keypad function 14 or Serial function F14 to set or determine the parameters of the external oscillator. The default on power-up will be whatever the values were at power-down.

Press "FUNC/ENTR" then "1" "4". The display will show:

External Osc  
FREQ \_1 MHz

Press the up or down arrow keys to select either 1, 5 or 10 MHz as the input frequency of the external oscillator. Press "FUNC/ENTR" to enter your choice. Now the display will show:

```
Ext Osc TUNING
SLOPE ±1.00e-06
```

Press the up or down arrow keys to toggle the sign of the external oscillator voltage control tuning slope which is entered in units of fractional frequency offset per volt. Press the right arrow key to move to the next digit. Either press the up or down arrow keys or alternately, directly enter numbers from the keypad for each of the remaining digits. The cursor will automatically advance to the next position when a number is entered directly. When the display shows the desired choice, press "FUNC/ENTR" to enter your choice. Now the display will show:

```
Ext Osc DAC
NOMINAL 0.50
```

Press the up or down arrow keys or directly enter the values desired for each digit to set the initial starting value of the external oscillator control voltage. The number input here sets the decimal fractional value of the full scale DAC output voltage swing to be used for the initial control voltage setting. The control voltage output may be configured to be either 0 to +10 Volts or -5 to +5 Volts via jumper JP5 on the 87-8XX GPS-XL board. Valid input range is 0.00 to 1.00. Once the desired value has been set, press "FUNC/ENTR". The display will show:

```
Ext Osc TEMP
STAB 5.00e-10
```

Using the same combination of arrow keys and direct digit entry, set the 0° to 60° C temperature stability of the external oscillator that is being controlled.

This value is used by the XL-AK to determine the optimal control loop averaging time so that performance under environmental stress of up to 8.3° C per hour temperature change does not degrade the output frequency stability significantly below that of the GPS system stability.

Inputting of better or worse temperature stability than the external oscillator actually has allows adjustment by the user of the control loop averaging time being used. This may be desirable when the user knows that the environment differs significantly from the rather stringent 8.3° C per hour assumption made by the XL-AK.

As an example, if the environment is known to exhibit maximum temperature changes on the order of 1° C per hour and the user would desire more filtering of the de-stabilizing effects of SA from the outputs of the XL-AK, a smaller value for the temperature stability of the external oscillator could be entered. The control loop averaging time would then be lengthened relative to the default averaging time assuming the true temperature stability were entered, by the square root of the ratio of the true temperature stability divided by the temperature stability actually entered.

After pressing "FUNC/ENTR" to set the external oscillator temperature stability, the display will show:

```
Save Ext Osc
Parameters? No
```

Use the up or down arrow key to toggle the desired action and press "FUNC/ENTR". The external oscillator parameters have now been saved to NVRAM and will be used immediately if the External

Oscillator has already been enabled via Keypad function 07 or Serial function F07. Otherwise they will be used when the external oscillator is next enabled.

3-115 reserved

### **3-116 KEYPAD FUNCTION 16 - EMULATION MODE ENABLE**

Use Keypad function 16 to enable or disable the emulation mode. When the emulation mode is "off", the Serial port responds to the "Mark III command set" as described in this section. When the emulation mode is "on", the Serial port responds to the "Mark II command set" as described in this section under SERIAL EMULATION COMMANDS. The emulation mode cannot be enabled or disabled via the Serial port.

The Mark II command set is composed of selected commands used on earlier TrueTime synchronized clocks. Therefore, most Serial programs written for use with these earlier models may be used with the current Mark III.

When the emulation is enabled or disabled, the Serial port will change modes, even if waiting to complete a command. When emulation mode is turned on, or power is applied when emulation is "on", the Serial port will enter MODE C, continuous time once per second, and the default format will be in effect. When emulation mode is turned off or power is applied to the unit when emulation is "off", the Serial port will enter the F08 command and send time once per second.

When emulation is "on", the Serial port acknowledges the commands C, T, F, and R. The as shipped default is "off". The default on power-up is whatever it was just before power-down.

Press "FUNC/ENTR" then "1" "6". The display will show:

Emulation mode	or	Emulation mode
<u>off</u>		<u>on</u>

Press the up- or down-arrow keys to toggle between "off" and "on". When the display shows the desired choice, press "FUNC/ENTR" and the command set will change.

#### **3-116.1 SERIAL PORT EMULATION COMMANDS**

As a convenience to our customers the TrueTime XL-AK emulates most of the Serial port commands of the older GPS-DC Mark II GPS Synchronized Clock. Most customer programs written to interface with the Mark II Serial port will also interface with the XL-AK Serial port if the emulation mode is enabled with Keypad function 16. Refer to the following Table for the available emulation mode commands.

## EMULATION MODE COMMANDS:

<u>COMMAND</u>	<u>MODE</u>	<u>DESCRIPTION</u>
C	Mode C	Continuous time, once per second
F	Mode F	Format Time Message
R	Mode R	Reset to default time format and Mode C
T	Mode T	Time on request

When the emulation mode is enabled with Keypad function 16, the Serial output defaults to Mode C. If the unit was in the emulation mode at power-down, it will power up in the emulation mode and default to Mode C. If the operator uses FUNCTION 03 to enter time before it appears on the front panel display, then the entered time will output at the Serial port.

### **3-116.2 MODE C - CONTINUOUS TIME, ONCE PER SECOND**

Use Mode C to set the Serial port to output the time message once each second. Mode C is the power-up default. To request Mode C send the ASCII character C to the Serial port. The format of the output string may be changed with Mode F. The default output string format is:

```
<SOH>DDD:HH:MM:SSQ<CR><LF>
```

where:

<SOH>	=	ASCII start-of-header character (Hex 01).
DDD	=	ASCII colon character.
HH	=	two-digit hours.
MM	=	two-digit minutes.
SS	=	two-digit seconds.
.	=	ASCII period character.
mmm	=	three characters for milliseconds.
Q	=	time quality character (see following).
<CR>	=	ASCII carriage return character.
<LF>	=	ASCII line feed character.

The time quality character may be one of the following:

SPACE	which indicates a worst-case error less than threshold 1.
.	which indicates a worst-case error greater than or equal to threshold 1.
*	which indicates a worst-case error greater than or equal to threshold 2.
#	which indicates a worst-case error greater than or equal to threshold 3.
?	which indicates a worst-case error greater than or equal to threshold 4.

The time quality character prior to satellite signal acquisition will be "?". Refer to SERIAL FUNCTION F13 - WORST-CASE TIME ERROR REQUEST for an explanation of worst-case error. The carriage return character <CR> start bit begins on the second, +0 to +1 bit period or  $\pm 1$  ms, whichever is larger.

To halt the output of time once each second send another command character to the Serial port. Non-command characters will be ignored if sent to the Serial port. If the command character C is sent to the Serial port prior to acquisition of time of year, then the port will output time elapsed from power-up once each second. Once correct time has been acquired, the port will output time of year.

### **3-116.3 MODE F - FORMAT THE TIME MESSAGE**

Use Mode F to alter the format of the time output string used in Mode C and Mode T. To set the format send a string of the form:

FDDD<C1>HH<C2>MM<C3>SS<C4>mmmQ

where:

F	=	Mode F command.
DDD	=	three characters for days.
<C1>	=	character that will be transmitted between the days and hours.
HH	=	two characters for hours.
<C2>	=	character that will be transmitted between the hours and minutes.
MM	=	two characters for minutes.
<C3>	=	character that will be transmitted between the minutes and seconds.
SS	=	two characters for minutes.
<C4>	=	character that will be transmitted between the seconds and milliseconds.
mmm	=	three characters for milliseconds.
Q	=	single character for the time quality.

If an X is used as a character in any character position, including the time quality character position, that position and its data will be omitted from the format. Any other character except a mode command character enables that position in the format.

There are no character transmissions until formatting is terminated. There are three ways to terminate formatting: 1) If a command character is sent before completing the format string, the altered portion of the format is accepted and the remainder of the format is unchanged and the new mode is entered. 2) If an ASCII line feed character (Hex 0A) is sent before completing the format string, the altered portion of the format is accepted and the remainder of the format uses the default and the time is immediately output once in the new format. 3) If all 15 characters of the format string are entered, the port will immediately output time once in the newly selected format. This new format will be used for time output in both Mode C and Mode T.

Note that the milliseconds are not available in Mode C even though formatted. On power-up the format will revert to the default format. Further note that the response of F mode is only accurate to about  $\pm 1$  sec and is intended only to indicate the current format, not to provide time information.

Sample Entry: F123/12:34:66.789Q  
Response: <SOH>360/22:01:25.602\*<CR><LF>

Sample Entry: FXXX hh,mm,ss XXXX  
Response: <SOH> 22,01,25 <CR><LF>

Sample Entry: FDDDAXXT  
Response: <SOH>360A:01:25.602\*<CR><LF>



### **3-116.4 MODE R - RESET TO DEFAULT AND MODE C**

Use Mode R to reset to the default format and return to Mode C. Send the command character R to the Serial port and the port will respond by outputting time in the default format once per second. Any previous Mode F format is canceled.

The data and carriage return timing of the initial output string sent immediately following the command character R is not reliable. This is due to internal synchronization with the data rate.

### **3-116.5 MODE T - TIME ON REQUEST**

Use Mode T to request a single output of time to the nearest millisecond. Send the command character T to the Serial port. The unit will save the time of year as of 9 bits after the center of the start bit of the character T, then the port will immediately respond with a single time data string in the current format selected. The Serial port outputs no further data until it receives another command character. The format of the Mode T string may be altered using Mode F. The default format is:

<SOH>DDD:HH:MM:SS.mmmQ<CR><LF>

where:

<SOH>	=	ASCII start-of-header character (HEX 01).
DDD	=	three-digit day of year.
:	=	ASCII colon character.
HH	=	two-digit hours.
MM	=	two-digit minutes.
SS	=	two-digit seconds.
.	=	ASCII period character.
mmm	=	three characters for milliseconds.
Q	=	time quality character as described below.
<CR>	=	ASCII carriage return character.
<LF>	=	ASCII line feed character.

The time quality character may be a:

SPACE	which indicates a worst-case error less than threshold 1.
.	which indicates a worst-case error greater than or equal to threshold 1.
*	which indicates a worst-case error greater than or equal to threshold 2.
#	which indicates a worst-case error greater than or equal to threshold 3.
?	which indicates a worst-case error greater than or equal to threshold 4.

If a command character T is sent to the Serial port prior to the acquisition of time, the Serial port will output time elapsed from power-up.

### **3-117 KEYPAD FUNCTION 17 - SLOW CODE SETUP (OPTION)**

Use function 17 to control the Slow Code output. This output provides one pulse per minute, primarily for placing timing marks on drum recorders. Each pulse edge is aligned to within a few nanoseconds of the 1PPS output, with the rising edge at the start of a minute. The as shipped default values are:

Once per minute pulse 2 seconds long.  
Once per hour pulse 4 seconds long.  
Once per day pulse 6 seconds long.

The default values on power-up will be those in use just prior to power-down.

Press "FUNC ENTR", then "1" "7". The display will show:

Slow Code minute  
pulse 02 sec

or a different number of seconds. This means that the once per minute slow code pulse will be 2 seconds long. Press the right or left arrow keys to position the cursor beneath the digit that you want to edit. Press the up or down arrow keys to scroll through the possible digit choices. Alternatively, directly enter the numbers using the keypad. The cursor will advance to the next digit automatically. When the display shows the value that you desire for the minute pulse width, press "FUNC/ENTR" and the display will show:

Slow Code hour  
pulse 04 sec

or a different number of seconds. This means that the once per hour slow code pulse will be 4 seconds long. Using the same combination of arrow keys and direct digit entry, when the display shows the desired value for the hour pulse width, press "FUNC/ENTR" and the display will show:

Slow Code day  
pulse 06 sec

or a different number of seconds. This means that the once per day slow code pulse will be 6 seconds long. Using the same combination of arrow keys and direct digit entry, when the display shows the desired value for the hour pulse width, press "FUNC/ENTR." The display will return to the status display, completing the entry of the slow code pulse widths.

If the function is aborted by pressing the TIME, STATUS, or POSITION keys before the third press of the "FUNC/ENTR" key, none of the changes will take effect.

Any of the 3 pulses may be set for widths between 0 and 59 seconds. A value of 0 means that the pulse will be absent from the Slow Code output.

### **3-118 KEYPAD FUNCTION 18 - SOFTWARE VERSION REQUEST**

Use keypad function 18 to obtain information about the current version of the software installed in the unit.

Press "FUNC/ENTR", then "1" "8". The display will show, for example:

TRUETIME Mk III  
sys ver 020

Press any of the arrow keys, to change the display to the clock-specific version. For example:

```
GPS-XL V1.036
182-6064v004
```

Repeated presses of the arrow keys will switch back and forth between the two displays.

The example shown indicates that the system software is version 20, the GPS-XL version is 1.036 and the clock-specific software is PART NO. 182-6064 version 004.

To return to the status display, press the "FUNC/ENTR", or the "STATUS" button.

3-119 through 3-127 reserved

### **3-128 KEYPAD FUNCTION 28 - TIME INTERVAL/EVENT TIMING INPUT (OPTION)**

Refer to manual Section 1-41 for specifications on the Time Interval/Event Timing Input. Use this function to measure the relationship of either periodic or randomly occurring events to the internal time of the XL-AK.

The Time Interval (TI) mode is best suited to periodic events such as measuring an externally applied 1PPS input. In this mode the reported time interval is expressed as the fractional part of a second between the XL-AK 1PPS which starts the count and the external 1PPS which stops it.

The Event Timing (ET) mode is suited to randomly occurring events whose time of occurrence is needed to a high accuracy. In this mode, the reported event time is expressed as a complete day-of-year through nanoseconds timetag.

Press "FUNC/ENTR", "2","8". The display will show:

```
Select TI or ET
Time Interval
```

Press the up or down arrow key to toggle between the two modes of operation. When the desired mode is displayed, press "FUNC/ENTR" to set it. The display will show one of these formats for the measurements:

```
TI:
.123456789
```

or

```
ET: 123:24:12:60
.123456789
```

Pressing "FUNC/ENTR" will abort measurement and return to the previous menu allowing selection of the TI/ET mode. Pressing any of these keys will abort the TI/ET function: "TIME", "STATUS" or "POSITION".

### **3-129 KEYPAD FUNCTION 29 - FREQUENCY MEASUREMENT INPUT (OPTION)**

Refer to manual Section 3-229 "SERIAL FUNCTION F29 - FREQUENCY MEASUREMENT INPUT (OPTION)" for a detailed operating description of this function. The keypad version offers a sub-set of the capabilities available in the Serial function version.

This function allows the user to set up periodic high resolution fractional frequency offset measurements of an externally applied 1, 5 or 10 MHz input relative to the GPS disciplined internal or external oscillator. These measurements are then displayed at the user set interval until another key is pressed.

Press "FUNC/ENTR", "2","9". The display will show:

```
External Freq
 10 MHz
```

Use the up or down arrow keys to select the correct input frequency for the XL-AK to measure. Press "FUNC/ENTR" to enter the selection. The display will now show:

```
Meas Interval
 000001 sec
```

Use a combination of right and left arrow keys and either the up and down arrow keys or direct digit entry to set the frequency measurement interval. Press "FUNC/ENTR" to enter the selection. After completion of the first measurement, the display will show:

```
Ext Freq XX:XX:XX
+x.xxxxxxxxxxe-xx
```

where XX:XX:XX is the time stamp of the endpoint of the displayed measurement and +x.xxxxxxxxxe-xx is the fractional frequency offset measurement. These measurements will continually be displayed at the interval selected until any of these keys is pressed: "FUNC/ENTR", "TIME", "STATUS", or "POSITION".

3-130 reserved

### **3-131 KEYPAD FUNCTION 31 - BACKLIGHT ENABLE (OPTION)**

Use function 31 to turn "on" or "off" the display back light. The as shipped default is "on". The default on power-up is whatever it was before power-down. The backlight is standard on the alphanumeric display, however, the backlight control is optional and may not be enabled on your particular unit.

Press "FUNC/ENTR" then "3" "1". The display will show:

```
Backlight   or   Backlight
  off              on
```

Press the up or down arrow keys to toggle between "off" and "on". When the display shows the desired choice, press "FUNC/ENTR" and the backlight will respond.

3-132 through 3-149 reserved

### **3-150 KEYPAD FUNCTION 50 - POSITION ENTRY/REQUEST**

Use keypad function 50 to enter or request the current antenna position. Since function 50 returns the most recent fix computed by the GPS core receiver, not the long term averaged position which is calculated during the AUTO mode of operation and reported via either Keypad or Serial function 56, its use is mainly for initializing the approximate position of the GPS core receiver at new installations or after loss of non-volatile RAM back-up power.

The as shipped default for position is that of the TrueTime factory in Santa Rosa, California. The position on subsequent power-ups will be the same as it was on the previous power-down.

Press "FUNC/ENTR", then "5" "0". The display will show:

Latitude  
N 38 23'53.9"

Press the right or left arrow keys to position the cursor beneath the character that you want to change. Press the up or down arrow keys to scroll through the possible choices. Alternately, numbers may be directly entered using the keypad. The cursor will automatically advance to the next position. When the display shows the desired Latitude, press "FUNC/ENTR" and the display will show:

Longitude  
W 122 42'53.0"

Using the same combination of arrow keys and direct digit entry, when the display shows the desired value for Longitude, press "FUNC/ENTR" and the display will show:

Altitude  
+000055 Meters

Using the same combination of arrow keys and direct digit entry, when the display shows the desired value for Altitude, press "FUNC/ENTR" and all of the new position data will be entered. To abort without changing the initial position data, press the "STATUS" button any time before the final "FUNC/ENTR". If the user attempts to enter a value that is out of the acceptable range the display will show the message:

Value error!  
re-enter

and the user will be given a chance to re-enter the correct position value.

### **3-151 KEYPAD FUNCTION 51 - ANTENNA CABLE DELAY ENTRY/REQUEST**

Use function 51 to request or enter a fixed delay to compensate for the antenna cable. The as shipped default is +60 nS. **When the downconverted antenna is being used, 200 nS should be subtracted from the cable delay entered here.** The value is held in NVRAM.

Press "FUNC/ENTR", then "5" "1". The display will show:

```
Cable delay
±000000060 nS
```

Press the right or left arrow keys to position the cursor beneath the digit that you want to change. Press the up or down arrow keys to scroll through the possible choices. Alternately, numbers may be directly entered using the keypad. The cursor will automatically advance to the next position. When the display shows the desired antenna cable delay, press "FUNC/ENTR" to enter the data. The acceptable range of delays is from +001000000ns to -001000000ns. *Positive delays entered here will advance the XL-AK timing outputs while negative delays will retard them.*

### **3-152 KEYPAD FUNCTION 52 - DISTRIBUTION CABLE DELAY ENTRY/REQUEST**

Use function 52 to request or enter a fixed delay to be used for compensating the timing outputs for distribution cable delays between the XL-AK and the point of use of the timing signals. Antenna cable delay compensation should not be performed using this function. Use function 51 for antenna cable delay. The default is 0 nS. The value is held in NVRAM.

Press "FUNC/ENTR", then "5" "2". The display will show:

```
Cable delay
±000000000 nS
```

Press the right or left arrow keys to position the cursor beneath the digit that you wish to change. Press the up or down arrow keys to scroll through the possible choices. Alternately, numbers may be directly entered using the keypad. The cursor will automatically advance to the next position. When the display shows the desired delay, press "FUNC/ENTR" to enter the data. The acceptable range of delays is from +001000000ns to -001000000ns. *Positive delays entered here will advance the XL-AK timing outputs while negative delays will retard them.*

### **3-153 KEYPAD FUNCTION 53 - OPERATIONAL MODE ENTRY/REQUEST**

Use function 53 to select the operating mode, either AUTO, SURVEY or TIME. These operating modes are explained in detail at the beginning of this section. The as shipped default is AUTO mode. The default on power-up is the mode in use before power-down.

Press "FUNC/ENTR", then "5" "3". The display will show:

```
AUTO / TIME Mode
AUTO
```

Press the up or down arrow keys to scroll through the possible operating modes. When the display shows the desired mode, press "FUNC/ENTR" to enter your choice.

When the optional SURVEY mode of operation is available and is selected, either the STATIC or DYNAMIC sub-mode of SURVEY operation must be selected, the display will show:

```
Dynamic Mode
STATIC
```

Press the up or down arrow keys to scroll through the possible SURVEY operating sub-modes. When the display shows the desired sub-mode, press "FUNC/ENTR" to enter your choice.

3-154 reserved

### **3-155 KEYPAD FUNCTION 55 - ALTITUDE UNITS ENTRY/REQUEST**

Use function 55 to select the units that altitude will be expressed in, either feet or meters. The as shipped default is meters. The default on power-ups is whatever unit was in use at power-down.

Press "FUNC/ENTR", then "5" "5". The display will show:

Altitude mode	or	Altitude mode
<u>M</u> eters		<u>F</u> eet

Press the up or down arrow keys to toggle between "Meters" and "Feet". When the display shows the desired units of measure, press "FUNC/ENTR" to enter your choice.

### **3-156 KEYPAD FUNCTION 56 - AVERAGE POSITION ENTRY/REQUEST**

Use keypad function 56 to enter or request the averaged, hence accurate, current antenna position. Its main use is to provide a means of setting an accurate, surveyed position for use in the TIME mode of operation. Positions provided to the XL-AK via function 56 should be more accurate than 10 meters, otherwise better results may be obtained via AUTO mode, unless satellite visibility at the site is too poor to provide three dimensional positioning.

The as shipped default position is N 00d00'0.0" E 000d00'0.0". The position on power-up will be the same as it was on power-down. An averaged position returned via function 56, which subsequently becomes in error by more than 1 km, either due to transport of the receiver and antenna or error in the initial entry, will be cleared and recalculated automatically once positioning begins at the new site and the error is detected.

To determine or modify the present position press "FUNC/ENTR", "5","6" and the display will show:

Averager Count	or	Entered Average
XXXXX/90000		Position

Indicating either that the present average position is based on XXXXX position fixes, and that 90000 such fixes will be averaged to complete the accurate position determination or that the current averaged position was entered. Press "FUNC/ENTR" again to display:

Ave. Latitude  
N DD MM'SS.S"

By pressing a combination of arrow keys and/or direct digit entry, this latitude may be changed. When it is as desired, press "FUNC/ENTR" to display:

Ave. Longitude  
W DDD MM'SS.S"

By pressing a combination of arrow keys and/or direct digit entry, this longitude may be changed. When it is as desired, press "FUNC/ENTR" to display:

Ave. Altitude  
+XXXXXX Meters

By pressing a combination of arrow keys and/or direct digit entry, this height above the WGS-84 ellipsoid may be changed. When it is as desired, press "FUNC/ENTR" to display:

Enter average  
position? No

This choice will only be made available if the XL-AK is operating in the TIME mode. Use the up or down arrow key to toggle to the desired response and press "FUNC/ENTR" to either cancel entry or complete it.

3-157 through 3-159 reserved

### **3-160 KEYPAD FUNCTION 60 - SATELLITES LIST REQUEST**

Use function 60 to list tracked or bad satellites and to see the relative signal strength of the tracked satellites.

Press "FUNC/ENTR", then "6", "0". The display will show:

List sats:  
Tracked

Press the up or down arrow keys to toggle between "Tracked" and "Bad". Once the type of list has been selected, press "FUNC/ENTR" again. The display will show:

Tracked Sats: or Bad Sats:  
#14 +13.65 #14

depending on which list was requested. Some other Satellite number may display. When observing Tracked Sats the number following the satellite number is the relative signal strength of that satellite. Each time "FUNC/ENTR" is pressed the display will show the next Tracked or Bad Satellite number. When the list is complete the display will show:

Tracked sats: or Bad sats:  
End of list End of list

Press "FUNC/ENTR" again and the display will show the initial display. Press the "STATUS" button to exit function 60.

3-161 through 3-164 reserved



### **3-165 KEYPAD FUNCTION 65 - SATELLITE SELECT**

Use function 65 to select specific satellites for the receiver to track and to deselect satellites, i.e. instruct the XL-AK to ignore certain satellites. Selections will be retained in non-volatile memory. Press "FUNC/ENTR", then "6" "5". The display will show:

Sat# 14      or      Sat# 14  
Enabled                      Disabled

or some other satellite number. Press the up or down arrow key to toggle between "Enable" and "Disable". When the display shows the desired choice press "FUNC/ENTR". Each time "FUNC/ENTR" is pressed the display will show the next satellite and whether it is enabled or disabled until all satellites for which the GPS core receiver has data are displayed. Then the display will show:

End Press  
Enter to confirm

Press "FUNC/ENTR" to enter your selections. To abort without changing the status of the satellites press the "STATUS" button.

### **3-166 KEYPAD FUNCTION 66 - DAYLIGHT SAVING ENABLE**

Use function 66 to set the Daylight Saving Time entry and exit times. The as shipped default is "Off". The default on power-up will be the selection in use just prior to power-down.

Press "FUNC/ENTR", then "6" "6". The display will show:

Daylight Saving   or   Daylight Saving  
Off                                      Manual

Press the up or down arrow key to scroll between the choices. When the display shows the desired choice press "FUNC/ENTR" to enter your choice.

The display and all other time outputs indicate UTC without any DST adjustment if a time-zone offset of 00:00 is selected. Regardless of the time-zone offset there will be no DST adjustment if "Off" is selected for the DST function. Some local jurisdictions enter and leave DST at times other than those set by U.S. federal law. Therefore, TrueTime has included a "Manual" choice which allows the user to override the times of entry into and exit from DST by selecting his own. If "Manual" is selected for the DST function, the display will show:

Enter dst: 02:00  
1st Sun in Apr

or some other entry time and date. Press the right- or left-arrow keys to position the cursor beneath the character that you wish to change. Press the up- or down-arrow keys to scroll through the possible choices. Alternatively, directly enter the numbers using the keypad. The cursor will automatically advance to the next position. The hours may range from 0 to 23. The week may be "1st", "2nd", "3rd", "4th", or "Last". Any day of the week or month may be selected. The above display means that Daylight Saving Time will start at 2 a.m. local time on the first Sunday in April each year. DST transitions may be set to occur at any hour of the day, any day of the week or any month of the year with the following restriction: If either transition is less than 24 hours from the start or end of a year, the transition may not occur at the desired time.

When the display shows the desired entry time and date, press "FUNC/ENTR" again, and the display will show:

Leave dst: 02:00  
Last Sun in Oct

or some other entry time and date. Press the right or left arrow keys to position the cursor beneath the character that you wish to change. Press the up or down arrow keys to scroll through the possible choices. Alternatively, directly enter the numbers using the keypad. The cursor will automatically advance to the next position. The ranges are the same as before but the exit time must be later than the entry time otherwise DST will never be entered. When the display shows the desired exit time, press "FUNC/ENTR" to enter the selections. The data entry may be aborted at any time prior to pressing the last "FUNC/ENTR" by pressing either the "TIME", "STATUS", or "POSITION" keys.

Once the entry and exit times are entered, they will be retained in nonvolatile memory if the clock loses power or is turned off. If the nonvolatile memory is corrupted due to battery failure or any other cause, the entry time will default to 2:00 a.m. on the first Sunday in April and the exit time will default to 2:00 a.m. on the last Sunday of October.

The sequence of the count upon entry into DST is:

01:59:58  
01:59:59  
03:00:00  
03:00:01

assuming the entry time was 2:00 a.m.. The sequence upon exit from DST is:

01:59:58  
01:59:59  
01:00:00  
01:00:01

assuming the exit time was 2:00 a.m.

If the DST function is enabled or disabled when DST is already in effect, the display will take several seconds to respond. Each time zone transitions into and out of Daylight Saving Time independently. This means that if the current time zone just entered DST and the time zone offset is then changed by means of keypad function 01 to a time zone in which the local time of the transition has not yet occurred, the standard time for that zone will be displayed. If the original time zone setting is restored, its time will remain in DST.

3-167 reserved

### **3-168 KEYPAD FUNCTION 68 - YEAR ENTRY (GPS EPOCH MANAGEMENT)**

The GPS week number sent from the satellites has only 10 bits of precision, so that 1024 weeks from January 6, 1980 (GPS week 0) it rolls back to 0. To correctly calculate calendar dates after this roll point, firmware keeps track of the current year so that it can construct an absolute, non-rolling week number since January 6, 1980.

The firmware has the current year embedded in code, and will properly handle dates through the year 2015. In addition, as the clock advances to each new year, the current year is updated and used in future calendar calculations, thus calculations beyond 2015 are handled properly. No user intervention is required as long as the current year saved in non-volatile memory is intact, and so long as the clock runs locked to GPS at least once each 5 years to allow the year to be updated. If after 2015, the current year saved in non-volatile memory is lost, or the clock is not locked to GPS within 5 years of the last year saved in non-volatile memory, then Function 68 can be used to manually enter the current year. Years prior to 1996 are not accepted, and entering a future year may cause incorrect calendar date calculations.

To request the current year setting via Keypad Function 68, perform the following steps.

Press "FUNC/ENTR" "6" "8" and the display will show:

```
Set current year
_1996
```

The year displayed will be the year saved in non-volatile memory used in the calendar calculations. To change it, enter the current year, then press "FUNC/ENTR". The display will prompt with:

```
Save year?
No
```

To save, use the up arrow key to change "No" to "Yes", then press "FUNC/ENTR".

### **3-169 KEYPAD FUNCTION 69 - SELECT LOCAL/STANDARD/GPS/UTC TIME**

Use function 69 to select between LOCAL, STANDARD, GPS or UTC time. The selected time type will be displayed and sent out on the IRIG-B and Serial ports. The as shipped default is the UTC time format. The power-up default will be whatever mode was selected prior to power-down.

Description of the various time types:

GPS: The time determined by primary atomic frequency standards. This type of time does not include leap seconds. Therefore, it differs from UTC time.

UTC: Universal Time Coordinated. This time is related to the local solar mean time at Greenwich Meridian. This time is adjusted once in a while to compensate for earth's rotational variations.

STANDARD: This time equals UTC plus the local time zone offset.

LOCAL: This time equal STANDARD plus Daylight Saving Time offset, when required.

Standard and Local times require the proper setting of the time zone offset (Function 01). In addition, Local time requires that Daylight Saving Time be properly set (Function 66), if applicable. The 12/24 hour mode (Function 02) is applied to all the above time types (GPS, UTC etc.).

Press "FUNC/ENTR", then "6" "9". The display will show:

```
Select Time Type
<Time Type>
```

where <Time Type> is either LOCAL, STANDARD, GPS or UTC.

Press the up or down arrow keys to toggle between LOCAL, STANDARD, GPS and UTC. When the display shows the desired format, press "FUNC/ENTR" to enter your choice.

3-170 reserved

### **3-171 KEYPAD FUNCTION 71 - OSCILLATOR STATISTICS REQUEST**

Use keypad function 71 to request the internal or external (when operating in the optional External Oscillator enabled mode, see Function 07) oscillator's phase, frequency offset, drift rate and DAC value. The phase is the instantaneous error in seconds between the oscillator and the control loop zero servo point as reported by the core GPS module. The frequency offset is computed using an averaging time that is equal to the effective averaging time of the oscillator controller. The oscillator drift rate is computed using a 24 hour average and is the daily drift rate of the oscillator. The oscillator DAC value is the signed 16 bit integer which controls the DAC output voltage. It ranges from 32767 to -32768.

"Oscillator phase" is the instantaneous error between the XL-AK timing outputs and GPS. Press "FUNC/ENTR" "7" "1" and the display will show:

```
Osc Phase  
-5.788e-09 s
```

indicating that the XL-AK timing was most recently reported to be approximately 6 nanoseconds late. This number has the full effects of Selective Availability superimposed upon it. The oscillator control loop servos the mean of this number to zero.

"Oscillator offset" is the frequency offset or error with respect to the GPS frequency. Press "FUNC/ENTR" and the display will show:

```
Osc Offset  
-2.150e-11
```

indicating that the internal or external oscillator frequency is less than GPS by approximately 2 parts in  $10^{-11}$ .

"Oscillator drift" is the change in oscillator frequency per day. Press "FUNC/ENTR" again and the display will show:

```
Osc Drift  
3.990e-12/DAY
```

indicating that the internal or external oscillator frequency is changing positively with respect to GPS by approximately 4 parts in  $10^{-12}$  per day.

"Oscillator DAC" is the signed 16 bit DAC control integer which sets the DAC output voltage to control the internal or external oscillator. Press "FUNC/ENTR" again to display:

```
DAC  
16368
```

indicating that the DAC output voltage is at either +2.5 volts or +7.5 volts depending upon whether the GPS-XL Module's DAC range setting jumper JP5 is off or on, respectively.

### **3-172 KEYPAD FUNCTION 72 - FAULT STATUS REQUEST**

Keypad function 72 displays the status of certain fault detectors within the XL-AK. These are currently limited to the status of the Antenna feed circuit, the PLL synthesizer lock status and GPS lock status. Press "FUNC/ENTR", "7","2" and the display will show:

Fault Status  
Antenna: XXX

where XXX is one of "OK", "OPEN", or "SHORT". Pressing the up or down arrow keys or "FUNC/ENTR" will display the next status indicator:

Fault Status  
PLL: XXXXXXXX

where XXXXXXXX is either "OK" or "UNLOCKED". Pressing the up or down arrow keys or "FUNC/ENTR" will display the next status indicator:

Fault Status  
GPS: XXXXXXXX

where XXXXXXXX is either "LOCKED" or "UNLOCKED".

### **3-173 KEYPAD FUNCTION 73 - REQUEST/SET ALARM STATUS/CONTROL**

This function allows the user to control which conditions will signal an alarm or fault through the 87-8XX GPS-XL Module open collector output at P46B pin 1 (OPTION), or through relay contacts (OPTION) on the 86-690 "L" board (if installed). The user may also monitor the status of the individual indicators which may contribute to the summary alarm outputs. In addition, a latched fault indication on each of the individual faults will be shown on the alphanumeric display by an asterisk character in the bottom right-most character position. This indication is useful in determining whether transient faults are occurring.

Keypad Function F73 allows the operator to scroll through the fault conditions that can affect the alarm outputs, and enable or disable each one's contribution to the alarm outputs. The fault condition is sampled on entering each fault display. At any time, the user may exit F73 without changing the alarm mask settings by pressing TIME, STATUS, or POSITION.

Press FUNC/ENTR, then "73", and the screen displays:

Clock Status  
GPS: <locked status>

where <locked status> can be "Locked" or "Unlocked", indicating whether the clock is locked to GPS within specifications.

To proceed, press FUNC/ENTR. The next screen displays:

Position Status  
<ave. status>

where <ave. status> summarizes the state of the position averaging process, and can be "Full Accuracy", "Position Approx.", "Position Unknown", or "Pos, Time Unknown". When the unit is operated in AUTO mode, and has obtained its first 3-D position fix, the Position Status is "Position Approx.". When the position averaging process is completed, switching the clock into TIME mode, we have reached "Full Accuracy". "Full Accuracy" is also displayed if the unit has a measured 3-D position and is manually switched into TIME mode, or if the operator enters an assumed good position while in TIME mode. When operated in the SURVEY mode and the unit has a measured position, this screen will indicate "Position Approx."

The remaining items are fault conditions, which can be individually enabled or disabled from affecting the alarm output(s). The <en> field is either "En" or "Dis" and can be toggled with the Up/Down arrow keys to Enable or Disable each fault condition. These mask settings will be changed only if requested at the end of all of the fault items.

Major Alarm: <en>  
PLL: <pll status>

<pll status> can be "OK" or "Unlocked". In some models not having a 10 MHz auxiliary oscillator, an indication of "Unlocked" is normal since the hardware PLL is not used.

Major Alarm: <en>  
Antenna: <ant. status>

<ant. status> can be "OK", "Short" or "Open". This indicates detection of improper load conditions on the antenna feed.

Major Alarm: <en>  
Receiver: <rec. status>

<rec. status> can be "OK", or "Fault". A "Fault" indicates there is some problem with the GPS receiver, such as it is failing to communicate with the host processor.

Major Alarm: <en>  
NV RAM: <nvram status>

<nvram status> can be "OK" or "Error". If any checksum errors were found on recalling any non-volatile memory blocks, or one or more blocks were missing and were created with default values, then this <nvram status> will be "Error". This may occur the first time the unit is powered up, or if some options have just been installed and new non-volatile memory blocks have been created for their use.

If <nvrn status> is "Error", then the next item will be

Clear NV RAM  
fault? <resp>

where <resp> can be toggled between "No" or "Yes" by the Up/Down arrow keys. After the operator has confirmed that all settings are correct this can be used to cancel the error, so that future errors can be caught.

Major Alarm: <en>  
Timeout: <timeout status>

<timeout status> can be "OK" or "Fault". "Fault" indicates that the time error has exceeded the time error threshold for more than Timeout seconds.

The timeout delay can be set by the next dialog:

Timeout delay  
<timeout> s

where <timeout> is in seconds between 0 and 86400 (1 day), and sets the delay from when the time error threshold is exceeded and when the Timeout fault occurs.

Minor Alarm: <en>  
Time Error: <TE status>

<TE status> can be "OK" or "Fault" and indicates that the estimated time error (available through Function 13) exceeds the alarm time error threshold.

The time error threshold is set by the next dialog:

Time threshold  
<threshold> nS

where <threshold> is in nanoseconds. If this is set to 0, then the Time Error fault occurs when the clock initially determines it is unlocked.

Minor Alarm: <en>  
Tracking: <tracking status>

<tracking status> can be "OK" or "Fault". This generally indicates whether we are receiving and decoding satellite information.

Minor Alarm: <en>  
Tuning: <tuning status>

<tuning status> can be "OK" or "Fault". If the oscillator is near the limits of the range that it can be steered by the DAC, then <tuning status> becomes "Fault" indicating that the oscillator may need to be checked and readjusted soon.

Minor Alarm: <en>  
NV Battery: <bat. status>

<bat. status> can be "OK" or "Low". The battery B1, which is used to maintain non-volatile information in RAM when the power is off, is checked at power on. If it is below about 2.0 volts, a "Low" is indicated. The battery should then be replaced. This may also indicate that GPS-XL jumper JP1 has been left off, disconnecting the battery.

Minor Alarm: <en>  
Acquisition: <acq. status>

<acq. status> can be "OK" or "Flt". "Flt" indicates that the unit is still in the process of acquiring initial lock, and that it has not yet locked since power on. "OK" indicates that it has locked at least once, regardless of whether it is currently locked.

Led Blink: <resp>

<resp> can be "En" or "Dis". This entry controls the blinking of the front panel Red/Green Status LED on Model XL-AK-600 (refer to BLINK ENABLE/DISABLE in this section).

PowerOn m Alarm  
Suppress <resp> s

<resp> can be set to any value from 0 to 86400 (seconds). The Minor Alarm conditions may be delayed if power-on Minor Alarm SUPPRESS is set. The Minor Alarms will be suppressed until either the unit power-on time exceeds the Minor Alarm suppress time or the unit locks to GPS.

Clear Alarm  
Latch <resp>

<resp> may be either "No" or "Yes". If the response is "Yes", the asterisk characters indicating latched alarm faults will be cleared (until the fault occurs again).

If any alarm mask settings have been changed, the next dialog will be:

Save Alarm Mask?  
<resp>

<resp> can be toggled with the Up/Down arrow keys between "No" or "Yes". If the operator answers "Yes", and presses FUNC/ENTR, the alarm enable settings, timeout delay, and time error threshold requested by the operator are made the current settings and stored in nonvolatile memory.

XL-AK front panels include a Red/Green Status LED that is controlled by function 73. In general, faults only affect the LED if they are enabled. However, even if there is no enabled major or minor fault, the presence of the time error fault is indicated by a solid Green LED (if BLINK = ENABLE). Normal operation within the user-defined time error threshold is indicated by the Green LED blinking at a one pulse per second rate.

The LED has the following states (when BLINK = ENABLE):



Off	Power off
Solid Red	Major enabled alarm fault
Solid Orange	Minor enabled alarm fault, time error outside threshold.
Blinking Red/Orange	Minor enabled alarm fault, time error within threshold.
Solid Green	No enabled alarm faults, time error outside threshold.
Blinking Green	No enabled alarm faults, time error within threshold.

The Red/Green Status LED has the following states (when BLINK = DISABLE):

Off	Power off
Solid Red	Major enabled alarm fault
Solid Orange	Minor enabled alarm fault
Solid Green	No enabled alarm faults

In all Models of the XL-AK, the 87-8XX GPS-XL sub-assembly open collector alarm output at P46B pin 1 has the following states:

Off (High Z)	Power off
Off (High Z)	Error, major or minor enabled alarm fault.
On (Low Z)	Normal, no major or minor enabled alarm faults.

If the processor on the 87-8XX GPS-XL sub-assembly were to fail, resulting in a failure to trigger the watchdog timer, the watchdog timer would reset the processor and attempt to restart the system. During the processor reset, the LED output would be Red, and the alarm output transistor open collector would be off, indicating a fault. If the processor were unable to recover and resume triggering the watchdog timer, a succession of watchdog timer timeouts followed by resets would result, producing a blinking Red LED. At the same time, the open collector alarm output transistor might either be off, or might toggle between off and on following the repeated resets, indicating an alarm condition.

The default alarm mask settings are summarized below:

<u>Major Alarm</u>	<u>Default Alarm Mask</u>
PLL	Disabled
Antenna	Enabled
Receiver	Enabled
NV RAM	Enabled
Timeout	Disabled
<u>Minor Alarm</u>	<u>Default Alarm Mask</u>
Time Error	Enabled
Tracking	Disabled
Tuning	Disabled
NV Battery	Disabled
Acquisition	Disabled

3-174 through 3-178 reserved

### **3-179 KEYPAD FUNCTION 79 - WARM START**

This function issues a reset command to the Trimble SVeeSix GPS core module. It does not clear stored almanac and ephemeris data which are retained in battery-backed RAM.

A warm start is indicated when all other diagnostics have failed to return the XL-AK to tracking satellites.

Press "FUNC/ENTR", then "7" "9". The display will show:

```
Warm start?  
No
```

Press the up or down arrow keys to toggle between "No" and "Yes". When the display shows the choice you desire, press "FUNC/ENTR". If you choose "yes" this will initiate a warm start. To exit this function without performing a warm start press the "STATUS" key.

3-180 through 3-196 reserved

### **3-197 GENERAL SERIAL INPUT AND OUTPUT FORMAT**

Data may be sent to or requested from the Serial port by using various function commands and ASCII character strings. In general those functions which request status or data fit the form:

```
F<FUNC#><CR>
```

where:

F	=	ASCII character F or f.
<FUNC>	=	two-digit function number.
<CR>	=	ASCII carriage return character (Hex 0D).

The format for both data input and data output strings is:

```
F<FUNC#>[<SEP><FIELD>]<LT>
```

where:

F	=	ASCII character F or f.
<FUNC>	=	function number.
<SEP>	=	one or more separator characters; either space, comma or tab.
<FIELD>	=	data entry or request.
<LT>	=	line terminator, either a carriage return and line feed for output strings or a carriage return only for input strings.
[ ]	=	encloses a phrase that is repeated as often as necessary.

Output strings from the Serial port are kept to fixed lengths whenever possible. This means that numeric values will often contain many leading blanks. Numeric values are right justified so that the least significant digit is always in the same position in the string. Quantities that can be positive or negative will have a sign even if positive. This is done to simplify the task of programming computer systems that receive the data. The formats of the output strings are designed so that it is possible to request the state of a function and save the response string. Later that string can be sent to the unit to restore the original state of that function.

Input strings sent to the unit may be of variable length. The number of separators between fields may be varied. Numeric values may be entered with or without leading zeros. Where a sign is allowed, it may be omitted for positive quantities. String fields (such as "on" or "off") may be entered in upper or lower case, as can the "F" that starts all Serial function commands. All commands may be ended with a carriage return alone or by a carriage return line feed combination. Some fields of some commands are optional, and may be replaced by a semicolon. If a field is so replaced, the corresponding value will be left unchanged.

Incorrect entry may result in an error message as described under "SERIAL ERROR MESSAGES". Correct entries are acknowledged with OK<CR><LF>.

### **3-198 SERIAL ERROR MESSAGES**

The Serial port will respond with the message "ERROR 01 VALUE OUT OF RANGE" if the input string was in the correct format but contained a value, probably numeric, that was out of the range of acceptable values. Refer to the paragraphs explaining the function in use for the correct range of values.

Sample entry: F01 13:00<CR>  
Response: ERROR 01 VALUE OUT OF RANGE<CR><LF>

The Serial port will respond with the message "ERROR 02 SYNTAX" if it receives a string in an incorrect format. Refer to "GENERAL SERIAL INPUT AND OUTPUT FORMAT" in this section.

Sample entry: F03 LOCAD<CR>  
Response: ERROR 02 SYNTAX<CR><LF>

The Serial port will respond with the message "ERROR 03 BAD/MISSING FIELD" if the input string lacks a required field. Refer to the paragraph in this section explaining the Serial function in use.

Sample entry: F14 1E<CR>  
Response: ERROR 03 BAD/MISSING FIELD<CR><LF>

The Serial port will respond with the message "ERROR 05 NO SUCH FUNCTION" if the function number requested is not implemented.

Sample entry: F40<CR>  
Response: ERROR 05 NO SUCH FUNCTION<CR><LF>

### **3-199 SERIAL FUNCTION LIST**

At power-up, the Serial port outputs time once per second as described in function F08 until it receives a CTRL-C character (Hex 03). Then any of the following commands may be used:

<u>FUNCTION</u>	<u>DESCRIPTION</u>	<u>AS SHIPPED</u>	<u>POWER-UP DEFAULT</u>
F01	Time Zone Entry/Request	00	Last Entry
F02	12/24 Hour Format Entry/Request	24	Last Entry
F03	Time/Date Entry/Request	--	--
F05	Time Quality Enable/Setup	On	Last Entry
F06	Keypad Lockout Enable	Off	Last Entry
F07*	External Oscillator Enable	Off	Last Entry
F08	Continuous Time Once/Second Enable	On	On
F09	Time on Request Enable	Off	Off
F11	Time Output Format Entry/Request	DDD:HH:MM:SS.mmmQ	Last Entry
F13	Worst-case Time Error Request	--	--
F15	Exclusive Use Enable	Off	Off
F14*	Ext Osc Parameter Entry/Request	--	Last Entry
F15	Exclusive Use Enable	--	Off
F17*	Slow Code Setup	2,4,6 sec.	Last Entry
F18	Software Version Request	--	--
F26*	Programmable Pulse Output	see function	Last Entry
F28*	Time Interval/ Event Timing Input	Off	Off
F29*	Frequency Measurement Input	Off	Off
F50	Position Entry/Request	Santa Rosa, CA	Last Calc.
F51	Antenna Cable Delay Entry/Request	60 nS	Last Entry
F52	Distribution Cable Delay Entry/Request	0 nS	Last Entry
F53	Operational Mode Entry/Request	AUTO	Last Entry
F55	Altitude Units Entry/Request	Meters	Last Entry
F56	Average Position Entry/Request	N 00d00'0.0" E 000d00'0.0"	Last Calc.
F60	Satellites List Request	--	--
F65	Satellite Select	All	Last Entry
F66	Daylight Saving Enable	Off	Last Entry
F68	Year Entry (GPS Epoch Management)	--	Last Entry
F69	Select Local/Standard/GPS/UTC Time	UTC	Last Entry
F71	Oscillator Statistics Request	--	Last Calc.
F72	Fault Status Request	--	--
F73	Request/Set Alarm Status/Control	see function	Last Entry
F79	Warm Start	--	--

\* Optional Function

3-200 reserved

### **3-201 SERIAL FUNCTION F01 - TIME ZONE ENTRY/REQUEST**

Use Serial function F01 to select or determine the time zone offset. NOTE: Function 01 will provide time zone offset only when the XL-AK is in LOCAL or STANDARD time mode (refer to function 69). To request the offset send F01<CR> to the Serial port. The port will respond with the following character string:

F01<SEP><SIGN><HH>:<MM><LT>

where:

F	=	ASCII character F.
01	=	function number.
<SEP>	=	one or more separator characters: either space, comma or tab.
<SIGN>	=	either no character or + for positive offsets or - for negative offsets.
<HH>	=	one - or two-digit hours offset from +12 to -12 hours.
:	=	ASCII character for a colon.
<MM>	=	two-digit minutes offset.
<LT>	=	line terminator, either a carriage return and line feed for output strings or a carriage return only for input strings.

Sample request: F01<CR>  
Response: -4:30<CR><LF>

To set the time zone offset send a character string with the following format:

Sample entry: F01 -8:00<CR>  
Response: OK<CR><LF>

Sample request: F01<CR>  
Response: -8:00<CR><LF>

### **3-202 SERIAL FUNCTION F02 - 12/24 HOUR FORMAT ENTRY/REQUEST**

Use Serial function F02 to request or set the time display format. To determine the format send F02<CR> to the Serial port. The port will respond with the following character string:

F02<SEP><HH><LT>

where:

F	=	ASCII character F.
02	=	function number.
<SEP>	=	one or more separator characters: either space, comma or tab.
<HH>	=	12 or 24.
<LT>	=	line terminator, either a carriage return and line feed for output strings or a carriage return only for input strings.

Sample request: F02<CR>  
Response: F02 12<CR><LT>

To select 24 hour format, send the following character string:

Sample entry: F02 24<CR>  
Response: OK<CR><LF>

### **3-203 SERIAL FUNCTION F03 - TIME/DATE ENTRY/REQUEST**

Use Serial function F03 to enter or request time and date. To request time and date send F03<CR> to the Serial port. The port will respond with the ASCII character string:

F03<SEP><TYPE><SEP><mm>/<dd>/<yy><SEP><HH>:<MM>:<SS><LT>

where:

F	=	ASCII character F.
03	=	function number.
<SEP>	=	one or more separator characters: either space, comma or tab.
<TYPE>	=	either LOCAL or UTC.
<mm>	=	one- or two-digit month.
/	=	ASCII character slash.
<dd>	=	one- or two-digit day.
<yy>	=	two-digit year.
<HH>	=	one- or two-digit hours.
:	=	ASCII character for a colon.
<MM>	=	two-digit minutes.
<SS>	=	two-digit seconds.
<LT>	=	line terminator, either a carriage return and line feed for output strings or a carriage return only for input strings.

Sample request: F03<CR>  
Response: F03 UTC 01/07/91 02:48:29<CR><LF>

Sample entry: F03 LOCAL<CR>  
Response: F03 LOCAL 01/07/91 7:48:29<CR><LF>

Sample entry: F03 UTC<CR>  
Response: F03 UTC 01/07/91 2:48:29<CR><LF>

To set the time and date, send a character string with the format above to the Serial port. Either the date MM/DD/YY or the time HH:MM:SS may be omitted if they are replaced with a semicolon (;). Only valid times and dates are accepted.

The following entry sets the local date and time.

Sample entry: F03 LOCAL 10/3/03 20:07:04<CR>  
Response: OK<CR><LF>

The following entry uses a semicolon to omit the date field, thus setting the UTC (default) time, and leaving the date unchanged.

Sample entry: F03 ; 3:06:48<CR>  
Response: OK<CR><LF>

3-204 reserved

### **3-205 SERIAL FUNCTION F05 - TIME QUALITY ENABLE/SETUP**

Use function F05 to enable or disable the time quality indicators or to set the four worst-case-error thresholds. Refer to "SERIAL FUNCTION F08 - CONTINUOUS TIME ONCE PER SECOND" for a description of the time quality indication in the Serial time output string. As shipped, the time quality characters are enabled and the thresholds are set to 1000ns, 10000ns, 100000ns and 1000000ns.

The XL-AK will retain the values in use at power-down and use them for subsequent power-ups. Acceptable threshold value range: 200ns to 40000000000ns.

To determine if the time quality characters are enabled and what the thresholds are, send F05<CR> to the Serial port. The port will respond with the ASCII character string:

F05<SEP><STATE><SEP><FLAG><SEP><FLAG><SEP><FLAG><SEP><FLAG><LT>

where:

F	=	ASCII character F.
05	=	function number.
<SEP>	=	one or more separator characters; either space, comma or tab.
<STATE>	=	ON or OFF.
<FLAG>	=	one error threshold in nanoseconds, 1 to 11 digits with or without leading zeros.
<LT>	=	line terminator, either a carriage return and line feed for output strings or a carriage return only for input strings.

Sample request: F05<CR>  
Response: F05 ON 00000001000 00000010000 00000100000 00001000000

To enable, disable or set the thresholds of the time quality indicators send a character string with the following format:

Sample entry: F05 ON 1000 10000 100000 2000000  
Response: OK<CR><LF>

Note that although leading zeros are not required for data entry they will be included in any data response.

### **3-206 SERIAL FUNCTION F06 - KEYPAD LOCKOUT ENABLE**

Use Serial function F06 to enable or disable the keypad lockout feature. As shipped the keypad lockout is disabled. The state of the keypad lockout on power-up will be the same as it was at power-down. To determine if the keypad lockout is enabled send F06<CR> to the Serial port. The port will respond with the ASCII character string:

F06<SEP><STATE><LT>

where:

F	=	ASCII character F.
06	=	function number.
<SEP>	=	one or more separator characters: either space, comma or tab.
<STATE>	=	ON or OFF.
<LT>	=	line terminator, either a carriage return and line feed for output strings or a carriage return only for input strings.

Sample request: F06<CR>  
Response: F06 OFF<CR><LF>

To enable keypad lockout send the following string:

Sample entry: F06,ON<CR>  
Response: OK<CR><LF>

### **3-207 SERIAL FUNCTION F07 - EXTERNAL OSCILLATOR ENABLE (OPTION)**

Use Serial function F07 to enable or disable Phase Locking to an External Auxiliary Oscillator. The GPS-XL Module jumpers JP6, JP3 and JP4 must be configured to support the desired operation set with this command. The state of the external oscillator enable on power-up will be the same as it was on power-down. To determine if the external oscillator is enabled send F07<CR> to the Serial port. The port will respond with the ASCII character string:

F07<SEP><STATE><LT>

where:

F	=	ASCII character F.
07	=	function number.
<SEP>	=	one or more separator characters; either space, comma or tab.
<STATE>	=	ON or OFF.
<LT>	=	line terminator, either a carriage return and line feed for output strings or a carriage return only for input strings.

Sample request: F07<CR>  
Response: F07 ON<CR><LF>



To enable or disable the external oscillator send a character string with the following format:

Sample entry: F07 OFF<CR> or F07 ON<CR>  
Response: OK<CR><LF>

### **3-208 SERIAL FUNCTION F08 - CONTINUOUS TIME ONCE PER SECOND ENABLE**

Internal Trimble SVeeSix time will output once per second at the Serial port prior to acquisition of satellite signals. Time-of-year will output once per second after acquisition of satellite signals. Character transmission is continuous with the end of the stop bit of one character coinciding with the beginning of the start bit of the next character. The time output string format may be changed with Serial function F11. The default output string format is:

<SOH>DDD:HH:MM:SSQ<CR><LF>

where:

<SOH>	=	ASCII Start-of-Header character (HEX 01).
<CR>	=	ASCII Carriage Return character (HEX 0D).
<LF>	=	ASCII Line Feed character (HEX 0A).
DDD	=	day-of-year.
HH	=	hours.
MM	=	minutes.
SS	=	seconds.
mmm	=	milliseconds.
:	=	colon separator.
Q	=	time quality character.

The time quality character may be a:

SPACE	which indicates a worst-case error less than threshold 1.
.	which indicates a worst-case error greater than or equal to threshold 1.
*	which indicates a worst-case error greater than or equal to threshold 2.
#	which indicates a worst-case error greater than or equal to threshold 3.
?	which indicates a worst-case error greater than or equal to threshold 4.

The time quality character prior to satellite signal acquisition will be "?". Refer to SERIAL FUNCTION F13 - WORST-CASE-TIME ERROR REQUEST. The carriage return character <CR> start bit begins on the second, +0 to +1 bit time or  $\pm 1$  ms, which ever is larger. Time will continue to output once per second until the port receives a CTRL-C character (Hex 03). The port will ignore all other input until it receives a CTRL-C.

### **3-209 SERIAL FUNCTION F09 - TIME ON REQUEST ENABLE**

When the Serial port receives the command string F09<CR> it waits for a request in the form of an upper-case ASCII character T to output the time-of-day string. After a T is received, the current time is saved (with a resolution of 1ms) in a buffer and is then transmitted to the port. The port will continue to respond with time-of-day each time it receives a T until this function is canceled by sending a

CTRL-C character (Hex 03) to the port (all other input will be ignored until then). The default output string is as follows:

<SOH>DDD:HH:MM:SS.mmmQ<CR><LF>

where:

<SOH>	=	ASCII Start-of-Header character (HEX 01).
<CR>	=	ASCII Carriage Return character (HEX 0D).
<LF>	=	ASCII Line Feed character (HEX 0A).
DDD	=	day-of-year.
HH	=	hours.
MM	=	minutes.
SS	=	seconds.
mmm	=	milliseconds.
:	=	colon separator.
Q	=	time quality character. Refer to function 08 for values.

Sample entry: F09<CR>  
Second entry: T  
Response: <SOH>128:20:30:04.357\*<CR><LF>

3-210 reserved

### **3-211 SERIAL FUNCTION F11 - TIME OUTPUT FORMAT ENTRY/REQUEST**

Use Serial function F11 to request or enter the time output string format that is used by Serial functions F08 and F09.

When shipped, the format string will be set to the "null" string, causing the strings of the F08 and F09 outputs to take on their default values.

EXAMPLE F08: <SOH>DDD:HH:MM:SSQ<CR><LF> (Once per second time output mode)

NOTE: Milliseconds are never present in the output of F08 mode regardless of the format string entered with F11.

EXAMPLE F09: <SOH>DDD:HH:MM:SS.mmmQ<CR><LF> (Time on demand output mode)

where:

<SOH>	=	ASCII Start-of-Header character (Hex 01).
<CR>	=	ASCII Carriage Return character (Hex 0D).
<LF>	=	ASCII Line Feed character (Hex 0A).
DDD	=	day-of-year.
HH	=	hours.
MM	=	minutes.
SS	=	seconds.
mmm	=	milliseconds.
.	=	ASCII decimal point.

mmm        =       milliseconds.  
 :           =       colon separator.  
 Q           =       time quality character position.  
             characters for this position are: < >, <.>, <\*>, <#> and <?>

If non-volatile memory is corrupted due to battery failure or other cause the format string will be set to the "null" string.

When the unit returns the current format string in response to "F11<CR>" (as shown in the following example) the first character after the "F11" is always a blank and is not part of the format string but is only a separator.

Sample request:     F11<CR>  
 Response:           F11 <CR><LF>

To omit a character, other than <SOH> <CR> or <LF>, send a string of the form

F11<SEP>DDD:HH:MM:SS.mmmQ<CR>

with an upper case "X" in place of the character that you wish to omit. The <SOH>, <CR> and <LF> characters in the output strings of F08 and F09 are not subject to control by F11. <SEP> is one character only, either a space, comma or tab. Any character other than an upper case "X" in a numeric position will not affect the output of that position. The colons (:) or decimal point (.), however, may be replaced with any single ASCII character except null (Hex 00), carriage return, or line feed.

The format on power-up will be the format in use just before power-down. To request the return of the present format send F11<CR> to the Serial port. The string returned will contain X's in the positions that are omitted in the time output string.

Sample entry:       F11 XXXXXXMMSSS.mmmX<CR>  
 Response:           OK<CR>  
 F08 string output:  <SOH>12M34S<CR><LF>  
 F09 string output:  <SOH>12M34S.567<CR><LF>

The above format means that days hours and the first two colon separators are suppressed and the third and fourth separators are "M" and "S".

If the format string entered with F11 is terminated early with a carriage return, the remaining characters are enabled and assume their default values.

Sample entry:       F11<TAB>XXX|<CR>  
 Response:           OK<CR>  
 F08 string output:  <SOH>|10:45:01\*<CR><LF>  
 F09 string output:  <SOH>|10:45:01.234\*<CR><LF>

The above format means that days are deleted, the first separator is a vertical bar and all other characters are enabled and assume their default values.

When entering a new format string the character after "F11" is required but is ignored. To enter a "null" format string send "F11" followed by a space, followed by a carriage return.

Sample entry: F11 <CR>  
Response: OK<CR>  
F08 string output: <SOH>DDD:HH:MM:SSQ<CR><LF>  
F09 string output: <SOH>DDD:HH:MM:SS.mmmQ<CR><LF>

The above format means that all characters and separators are enabled and assume their default values.

If the current format string is "null", F11 will return a space character followed by a carriage return.

Sample entry: F11<CR>  
Response: F11 <CR>

The format string below explicitly enables all characters and has the same effect as a "null" format string:

Sample entry: F11 DDD:HH:MM:SS.mmmQ<CR>  
Response: OK<CR>  
F08 string output: <SOH>DDD:HH:MM:SSQ<CR><LF>  
F09 string output: <SOH>DDD:HH:MM:SS.mmmQ<CR><LF>

3-212 reserved

### **3-213 SERIAL FUNCTION F13 - WORST-CASE TIME ERROR REQUEST**

Use Serial function F13 to request the estimated worst-case time error due to oscillator drift during periods when satellites are not being tracked. The worst-case time error while tracking satellites is always 00.000000200 seconds. Time error begins to accumulate when the receiver loses contact with the satellite signal. The XL-AK calculates the worst-case time error based on the stability of the time base in use, either the internal or optional external oscillator (refer to function 14), and the time elapsed since loss of lock. The Serial port will report this calculated error when it receives the string F13<CR> and responds with the following ASCII character string:

F13<SP><ERROR><CR><LF>

where:

F	=	ASCII character F.
13	=	function number.
<SP>	=	ASCII space character.
<ERROR>	=	calculated worst-case error in seconds.
<CR>	=	carriage return character.
<LF>	=	line feed character.

Sample request: F13<CR>  
Response: F13 40.000000000<CR><LF>

### **3-214 SERIAL FUNCTION F14 - EXTERNAL OSCILLATOR PARAMETER ENTRY/REQUEST (OPTION)**

Use Serial function F14 to set or determine the external oscillator parameters. These parameters are used to properly configure the input circuitry and to calculate the control coefficients for disciplining the external oscillator. The settings on power-up will be the same as they were on power-down. To request the present values send F14<CR> to the Serial port. The port will respond with the following ASCII character string:

```
F14<SEP><FREQUENCY><SEP><TUNESLOPE><SEP><DACNOMINAL><SEP><TEMPSTAB><CR><LF>
```

where:

F	=	ASCII character F.
14	=	the function number.
<SEP>	=	one or more separator characters: space, comma or tab.
<FREQUENCY>	=	the external oscillator frequency in MHz, either 1, 5, or 10 signed
<TUNESLOPE>	=	fractional frequency offset/volt sensitivity of the external oscillator
<DACNOMINAL>	=	frequency control input in scientific format:sX.XXEsXX. decimal fraction of DAC full scale voltage for nominal DACsetting which corresponds to center frequency of the external oscillator: XX.
<TEMPSTAB>	=	unsigned peak-peak change in fractional frequency offset of the external oscillator over the range of 0 C to +60 C in scientific format: X.XXEsXX
<CR>	=	ASCII carriage return character (HEX 0D)
<LF>	=	ASCII line feed character (HEX 0A)

```
Sample request:  F14<CR>
Response:       F14 1 -2.12E-11 .50 3.00E-09<CR><LF>
```

To enter the external oscillator parameters send a character string with the following format:

```
Sample entry:   F14 5 1.00E-09 .25 5.00e-08<CR>
Response:      OK<CR><LF>
```

### **3-215 SERIAL FUNCTION F15 - EXCLUSIVE USE ENABLE**

At times it is advisable to prevent entry of data via the front panel keypad. When the exclusive use function is enabled by the Serial port, data entries may be made only via the Serial port. The front panel display will still respond to requests for data even if the Serial port has exclusive use. Use Serial function F15 to enable or disable or request the state of the exclusive use function. As shipped the exclusive use function is disabled. The state of the exclusive use function on power-up will be off. To enable or disable this function send a string of the form:

```
F15<SEP><STATE><CR>
```

where:

F	=	ASCII character F.
15	=	function number.
<SEP>	=	one or more separator characters: either space, comma or tab.
<STATE>	=	OFF if no port has exclusive use, OTHER if some other port has exclusive use, SELF if the Serial port has exclusive use or ON if enabling the Serial port.
<CR>	=	carriage return character

The state will change or, if another port has exclusive use, the port will respond with the string:

ERROR 04 EXCLUSIVE USE<CR><LF>

Sample request: F15<CR> (This asks for the state)  
Response: F15 OFF

Sample entry: F15 ON<CR> (This enables exclusive use)  
Response: OK<CR><LF>

Sample request: F15<CR> (This asks for the state)  
Response: F15 SELF

3-216 reserved

### **3-217 SERIAL FUNCTION F17 - SLOW CODE SETUP (OPTION)**

Use Serial function F17 to request or set the pulse widths of the optional slow code output. This output provides one pulse per minute, primarily for placing timing marks on drum recorders. The once per minute, once per hour and once per day pulses can each be set to a different length, or the same length with this function. The lengths can range from 0 to 59 seconds, whole numbers only. A length of 0 means that the pulse is absent.

Each pulse edge is aligned to within a few nanoseconds of the XL-AK's 1PPS pulse, with the rising edge at the start of a minute.

To determine the current pulse widths, F17<CR> to the Serial port. The port will respond with the ASCII character string:

F17<SEP><MIN><SEP><HR><SEP><DAY><LT>

where:

F	=	ASCII character F.
17	=	function number.
<SEP>	=	one or more separator characters: either space, comma or tab.
<MIN>	=	length in seconds of the once per minute pulse.

<HR> = length in seconds of the once per hour pulse.  
<DAY> = length in seconds of the once per day pulse.  
<LT> = line terminator, either a carriage return and line feed for output strings or a carriage return only for input strings.

Sample request: F17<CR>  
Response: F17 02 04 06<CR><LF>

To set pulse lengths of the slow code output, send a character string with the following format:

Sample entry: F17 1 2 3<CR>  
Response: OK<CR><LF>

This will set the once per minute pulse to 1 second width, the once per hour pulse to 2 seconds, and the once per day pulse to 3 seconds.

When shipped, the unit is set to have pulse widths of 2, 4, and 6 seconds for the minute, hour, and day pulses respectively. The widths will be retained when the unit is not powered.

### **3-218 SERIAL FUNCTION F18 - SOFTWARE VERSION REQUEST**

Use Serial function F18 to obtain information about the current version of the software installed in the unit. Send the string:

F18<CR>

and the XL-AK Serial port will respond with a string no longer than 80 characters.

Example: TRUETIME Mk III sys ver 020 GPS-XL v1.036 182-6064v004<CR><LF>

This string indicates that the system software is version 20, the GPS-XL version is 1.036 and the XL-AK specific software part number is 182-6064 version 004.

3-219 through 3-225 reserved

### **3-226 SERIAL FUNCTION F26 - PROGRAMMABLE PULSE OUTPUT**

The Programmable Pulse Output (PPO) is a standard output if the 86-690 "L" board is installed. If the 86-690 "L" board is installed, refer to manual section V for output specifications. Use Serial function F26 to enter or request the parameters for the Programmable Pulse Output, with resolution down to one millisecond.

To set the Programmable Pulse Output parameters, send a string to the Serial port in this format:

F26<SEP><START TIME><SEP><STOP TIME><CR><LF>

where:

F	=	ASCII character F.
26	=	function number.
<SEP>	=	one or more separator characters: either space, comma or tab.
<START TIME>	=	time to start the pulse, formatted like: <DAY>:<HOURS>:<MIN>:<SEC>.<MSEC>
<STOP TIME>	=	time to stop the pulse, formatted like: <DAY>:<HOURS>:<MIN>:<SEC>.<MSEC>
<CR>	=	ASCII Carriage Return character (HEX 0D).
<LF>	=	ASCII Line Feed character (HEX 0A).
<DAY>	=	3-digit day of year.
:	=	ASCII colon character.
<HOURS>	=	2-digit hours, in 24 hour form.
<MIN>	=	2-digit minutes.
<SEC>	=	2-digit seconds.
.	=	ASCII decimal point character.
<MSEC>	=	3-digit millisecond.

Sending F26 by itself will return the current Programmable Pulse Output time setting.

Sample request: F26<CR>  
Response: F26 123:18:33:23.324 124:23:32:43.321<CR><LF>

The user can specify both a Start Time and a Stop Time, in which case the rising edge will occur at the Start Time, and the falling edge will occur at the Stop Time. The times specified are compared with local time, which is UTC adjusted by the local offset. Leading zeros are required.

Sample entry: F26 001:00:00:00.000 002:00:00:00.000<CR>  
Response: OK<CR><LF>

This will produce a 1 day pulse on January 1.

Invalid times are rejected with the error message:

ERROR 02 SYNTAX

The user may place an 'X' in any digit position, in which case the Start Time (or Stop Time) will be any time that matches the non-'X' digits. This can be used to produce repetitive pulses from once per year up to 100 per second.

Sample entry: F26 XXX:XX:X0:00.000 XXX:XX:X1:00.000<CR>  
Response: OK<CR><LF>

This will emit a 1 minute pulse every 10 minutes, aligned with multiples of 10 minutes.

If only the Start Time is specified, a 1 millisecond pulse is generated with the rising edge starting at that time.



Sample entry: F26 XXX:XX:30:00.000<CR>  
Response: OK<CR><LF>

This will generate a 1 millisecond pulse on the half hour.

Either the Start Time or the Stop Time may be replaced with a semicolon, in which case that item will be unchanged by the command.

Sample entry: F26 ;XXX:XX:10:00.000<CR>  
Response: OK<CR><LF>

This will leave the Start Time set to whatever it was before, and will change the Stop Time to 10 minutes after the hour. If both the Start Time and the Stop Time match the current time, then the pulse is turned off.

Sample entry: F26 XXX:XX:XX:XX.2XX XXX:XX:XX:XX.XXX<CR>  
Response: OK<CR><LF>

The pulse would normally be turned on every second at 200 milliseconds, but the Stop Time also matches then, so the pulse will stay off.

To clear the output regardless of the time: F26 000:00:00:00.000 XXX:XX:XX:XX.XXX

To set the output regardless of the time: F26 XXX:XX:XX:XX.XXX 000:00:00:00.000

The default power-on Pulse Out setting is: F26 000:00:00:00.00 000:00:00:00.000

Since the day is day 000, the Start and Stop times never match.

When the power is turned off, the current setting is saved in non-volatile memory, to be restored when it is next turned on.

3-227 reserved

### **3-228 SERIAL FUNCTION F28 - TIME INTERVAL/EVENT TIMING INPUT (OPTION)**

Refer to manual section 1-41 for specifications on the Time Interval/Event Timing Input. Use Serial function F28 to request a time interval measurement or event times. Send a string of the form:

F28<SEP><MODE><CR>

where:

F	=	ASCII character F.
28	=	function number.
<SEP>	=	one or more optional separator characters; either space, comma or tab.
<MODE>	=	either TI for Time Event or ET for Event Timing. This field is optional with the default being ET.
<CR>	=	carriage return character.

If the mode was TI, the port will respond with a string of the form:

<NSEC><CR><LF>

where:

<NSEC> = 9-digit subsecond string  
<CR> = carriage return character.  
<LF> = line feed character.

The interval is expressed as a decimal fraction of seconds. The port will continue to update and output an interval measurement once each second until the Serial port receives a CTRL-C character.

Sample entry: F28 ti<CR>  
Response: .123456700<CR><LF>  
Meaning: The interval is 0.123456700 seconds

If the mode was ET, the port will respond with a string or strings of the form:

<DAY>:<HOUR>:<MIN>:<SEC>.<NSEC><CR><LF>

where:

<DAY> = 3-digit day of year.  
: = ASCII colon character.  
<HOUR> = 2-digit hours.  
<MIN> = 2-digit minutes.  
<SEC> = 2-digit seconds.  
<NSEC> = 9-digit subsecond string  
<CR> = carriage return character.  
<LF> = line feed character.

Up to ten events each second may be timed if the events are continuous. A burst of 100 events within 1.0 sec may be recorded. The resolution is 30 ns. Send a CTRL-C to exit this mode.

Sample entry: F28 ET<CR>  
Response: 111:22:33:44.123456700<CR><LF>

### **3-229 SERIAL FUNCTION F29 - FREQUENCY MEASUREMENT INPUT (OPTION)**

Refer to section 1-42 for information concerning the Frequency Measurement Input. Use Serial function F29 to set the measurement mode, input frequency and measurement interval parameters and to view the current settings and the measurement data.

This function provides the capability to measure the frequency of an externally applied 1, 5 or 10 MHz signal very accurately with respect to the disciplined XL-AK oscillator. The resolution of the measurements is 6 parts in  $10^{-11}$  divided by the Measurement Interval. The range of fractional frequency offset from the nominal input frequency which may be measured is +/- 500 PPM. The Measurement Interval may be specified in integer seconds over the range of 1 to 100,000 seconds.

Function 29 offers three modes of operation:

OFF	--	No measurements are reported in this mode.
QUERY	--	Measurements are reported only when requested in this mode.
PERIODIC	--	Measurements are continuously output at the specified interval in this mode until a CTRL-C is sent.

The measurement technique uses a heterodyne phase error multiplier approach to achieve high resolution at short sample periods. An important feature of this implementation is that "zero dead time" frequency measurements are performed. In essence the position in XL-AK internal time of a zero crossing of the externally applied frequency being measured is recorded, or "timestamped", once per measurement interval with 60 picosecond resolution. (In the QUERY mode of operation, the reception of the measurement request string causes a timestamp to be performed, rather than at a fixed repetitive rate as in the PERIODIC mode of operation). In addition, the number of zero crossings between successive timestamps is also recorded.

When it is time to perform a measurement, either because the selected interval in PERIODIC mode has elapsed or a QUERY mode measurement request has been received, the previous measurement timestamp is subtracted from the current one and the difference is divided by the number of zero crossings between these two timestamps. This result is the average period of the external frequency being measured over the interval. The reciprocal of this period is then compared to the nominal frequency to determine the fractional frequency offset. The timestamp reported with the resulting measurement is the ending timestamp of the two phase readings used to make the measurement. Since this ending timestamp is now the beginning timestamp for the next measurement, there is no "dead time" present in the measurements.

The reported timestamp resolution is sufficient to allow integrating the fractional frequency offset measurements to fully recover the relative phase of the external frequency source being measured versus the disciplined XL-AK internal or external oscillator.

To view the current settings, send a character string of the form:

F29<CR>

where:

F	=	ASCII character "F"
29	=	function number
<CR>	=	ASCII carriage return character, Hex 0D

The Serial port will respond with:

F29<SEP><MODE><SEP><FREQ><SEP><INTERVAL><CR><LF>

where:

<SEP>	=	separator character, either space, comma or tab.
<MODE>	=	either OFF, QUERY or PERIODIC.
<FREQ>	=	Input frequency in MHz, either 1, 5 or 10. This field is not sent if the mode is OFF.

<INTERVAL> = measurement interval in seconds, a decimal integer in the range of 1 to 100000. This field is not sent if the mode is OFF or QUERY.

To configure function F29, send a string in this format:

F29<SEP><MODE><SEP><FREQ><SEP><INTERVAL><CR>

If the MODE being set is OFF, then the Serial port will respond with:

OK<CR><LF>

Otherwise, the Serial port will respond with:

F29<SEP><TIMESTAMP><SEP><MODE><SEP><FREQ><SEP><INTERVAL><CR><LF>

where:

<TIMESTAMP> = dayofyear:hours:minutes:seconds.subseconds in this fixed field format: ddd:hh:mm:ss.nnnnnnnnn

This timestamp is the initial phase timestamp which will be used to compute the first fractional frequency offset measurement which will follow either from a QUERY or PERIODIC update.

In the PERIODIC mode of operation, measurements are continually output at the specified measurement interval until a CTRL-C character (Hex 03) is received. Reception of the CTRL-C character automatically sets the F29 mode to OFF. In PERIODIC mode, all characters sent to the XL-AK will be ignored until a CTRL-C is received. This mode is suitable for long term automated observation of the performance of an external frequency standard or for the calibration of free running timebase oscillators.

In the QUERY mode of operation, a measurement is computed and output each time that this string is received:

F29<SEP>F<CR>

where:

F = ASCII character "F".

In this mode, the measurement interval is the time in integer seconds between receptions of the above string. This mode is useful in matching the data rate of some other process which is concurrently being logged and is not necessarily periodic or synchronized with the XL-AK.

The measurement returned in either the QUERY or PERIODIC modes is sent in this format:

F29<SEP><TIMESTAMP><SEP><FFO><CR><LF>

where:

<FFO> = fractional frequency offset of the input frequency relative to its nominal frequency in this fixed field scientific notation format: sX.XXXXXXXXXXXEsXX

Sample command: F29 PERIODIC 10 100<CR>  
Response: F29 124:23:08:10.000956789 PERIODIC 10 MHZ 100 SEC<CR><LF>  
Result: A 10 MHz input frequency is continually measured and reported over second measurement intervals.

Sample measurement sent either from PERIODIC mode or on request from QUERY mode:

Response: F29 123:21:37:56.000894320 -2.89345678245E-04<CR><LF>

3-230 through 3-249 reserved

### **3-250 SERIAL FUNCTION F50 - POSITION ENTRY/REQUEST**

Use Serial function F50 to enter or request the current antenna position. Since function F50 returns the most recent fix computed by the GPS core module, not the long term averaged position which is calculated during the AUTO mode of operation and reported via Serial function F56, its use is mainly for initializing the approximate position of the GPS core module at new installations or after loss of non-volatile RAM back-up power.

The as shipped default for position is that of the TrueTime factory in Santa Rosa, California. The position on power-up will be the same as it was prior to power-down. To determine the present position send F50<CR> and the Serial port will respond with the following continuous one line string:

F50<SP><SIGN><SP><DEG>d<MIN>'<SEC>"<SP><SIGN><SP><DEG>d<MIN>'<SEC>"<SP><SP><SP><SP or -><ALT><UNITS><SP>pdop<SP><PDOP><LT>

where:

F = ASCII character F (f or F for input string).  
50 = function number.  
<SP> = ASCII space character.  
<SIGN> = N or S for latitude; E or W for longitude; or + or - for longitude, latitude or altitude (-) corresponds to S or W or no character, <SP> for + altitude.  
<DEG> = two-digit degrees for latitude or three-digit degrees for longitude.  
D = ASCII character d (d or D for input string always d in output string).  
<MIN> = two-digit minutes.  
' = ASCII character ' ( ' m or M for input string -- always ' in output strings).  
<SEC> = two-digit seconds + 1 digit 10ths of seconds.  
" = ASCII character " ( " s or S for input string -- always " in output string).  
<ALT> = altitude in feet or meters.  
<UNITS> = unit of altitude, either a M or m for meters or F or f for feet depending on the units selected with Serial function F55.

<PDOP> = 3 or 4 digit value of the position dilution of precision.  
 <LT> = line terminator, either a carriage return and line feed for output strings or a carriage return only for input strings.

Sample request: F50<CR>  
 Response: F50 N 38d23'51.3" W 122d42'53.2" 58m pdop 2.69<CR><LF>

To enter a position send a character string with the following format. Latitude, longitude or altitude may be omitted in the string provided they are replaced with a semicolon (;) character. The altitude units may be feet or meters.

Sample entry: f50 n 38d23'51.3" w 122d42'53.2" 10m<CR>  
 equivalent: F50 + 38D23M51.3S + 122D42M53.2S +10M<CR>  
 Response: OK<CR><LF>

Sample request: F50<CR> (after sending above string)  
 Response: F50 N 38d23'51.3" W 122d42'53.2" 10m pdop 2.69<CR><LF>

Sample entry: f50;;40m (with values from example above)  
 equivalent: F50; 40M  
 (no change to latitude or longitude - altitude now 40m)  
 Response: F50 N 38d23'51.3" W 122d42'53.2" 40m pdop 2.69<CR><LF>

NOTE: Altitude must be included in the position entry string - either a value or a (;) must be entered or a syntax error will occur (causing the entered string to be ignored).

### **3-251 SERIAL FUNCTION F51 - ANTENNA CABLE DELAY ENTRY/REQUEST**

Use Serial function F51 to enter or request the antenna cable delay. The default is 60ns. The delay for RG-58 cable is approximately 1.4 ns/foot and RG-59 cable is approximately 1.24 ns/foot. **When the downconverted antenna is being used, 200 ns should be subtracted from the cable delay entered here.** The value is held in NVRAM. To determine the present value send F51<CR> to the Serial port. The port will respond with the ASCII character string in the following format:

F51<SEP><SIGN><DELAY>ns<LT>

where:

F = ASCII character F (f or F for input string).  
 51 = the function number.  
 <SEP> = one or more space characters.  
 <SIGN> = either + or -  
 <DELAY> = 1 to 9 digit delay from +001000000ns to -001000000ns.  
 ns = nanoseconds (ns or NS for input string).  
 <LT> = line terminator, either a carriage return and line feed for output strings or carriage return only for input strings.  
 <SP> = ASCII space character.

Sample request: F51<CR>  
 Response: F51<SP><SP><SP><SP><SP><SP><SP><SP><SP>+60ns<CR><LF>

To enter a 1 millisecond cable delay send the following character string:

Sample entry: F51<SP>1000000NS<CR>  
Response: OK<CR><LF>

Sample request: F51<CR> (using entry from above)  
Response: F51<SP><SP><SP>+1000000ns<CR><LF>

### **3-252 SERIAL FUNCTION F52 - DISTRIBUTION CABLE DELAY ENTRY/REQUEST**

Use Serial function F52 to enter or request the distribution cable delay for compensating the timing outputs for delays between the XL-AK and the point of use of the timing signals. Antenna cable delay compensation should not be performed using this function. Use function F51 for antenna cable delay. The default is 0 ns. Typical delays for RG-58 = 1.4 ns/foot and RG-59 cables = 1.24 ns/foot. The value is held in NVRAM. *Positive delays entered here will advance the XL-AK timing outputs while negative delays will retard them.*

To determine the present value send F52<CR> to the Serial port. The port will respond with the ASCII character string in the following format:

F52<SEP><SIGN><DELAY>ns<LT>

where:

F	=	ASCII character F (f or F for input string).
52	=	the function number.
<SEP>	=	one or more space characters.
<SIGN>	=	either + or -
<DELAY>	=	1 to 9 digit delay from +001000000ns to -001000000ns.
ns	=	nanoseconds (ns or NS for input string).
<LT>	=	line terminator, either a carriage return and line feed for output strings or a carriage return only for input strings.
<SP>	=	ASCII space character.

Sample request: F52<CR>  
Response: F52<SP><SP><SP><SP><SP><SP><SP><SP><SP>+0nS<CR><LF>

To enter a 1 millisecond cable delay send the following character string:

Sample entry: F52<SP>1000000NS<CR>  
Response: OK<CR><LF>

Sample request: F52<CR> (using entry from above)  
Response: F52<SP><SP><SP>+1000000ns<CR><LF>

### **3-253 SERIAL FUNCTION F53 - OPERATIONAL MODE ENTRY/REQUEST**

Use Serial function F53 to select the operational mode, either AUTO, SURVEY (STATIC or DYNAMIC) or TIME. For an explanation of these modes refer to section 3-10, "OPERATIONAL MODES". The power-up default is the mode in use at power-down. To request the present mode send F53<CR> to the Serial port. The port will respond with the ASCII character string:

F53<SEP><MODE>:<SEP><#><SEP>SATS<LT>

where:

F	=	ASCII character F.
53	=	function number.
<SEP>	=	one or more separator characters; either space, comma or tab.
<MODE>	=	AUTO, SURVEY STATIC, SURVEY DYNAMIC or TIME.
:	=	ASCII colon
<SEP>	=	space
<#>	=	number of SV's being tracked
<LT>	=	line terminator, either a carriage return and line feed for output strings or a carriage return only for input strings.

Sample request: F53<CR>  
Response: F53 SURVEY STATIC: 6 SATS<CR><LT>

To enter TIME mode send the following character string:

Sample entry: F53<SP>TIME<CR>  
Response: OK<CR><LF>  
Sample request: F53<CR>  
Response: F53 TIME: 5 SATS<CR><LF>

3-254 reserved

### **3-255 SERIAL FUNCTION F55 - ALTITUDE UNITS ENTRY/REQUEST**

Use Serial function F55 to select the altitude units, either feet or meters. The as shipped default is meters. The altitude units at power-up will be the units in use at power-down. To request the altitude units presently in use, send F55<CR> to the Serial port. The port will respond with the ASCII character string:

F55<SEP><UNITS><LT>

where:

F	=	ASCII character F.
55	=	function number.
<SEP>	=	one or more separator characters; either space, comma or tab.



<UNITS> = FEET or METERS.  
 <LT> = line terminator, either a carriage return and line feed for output strings or a carriage return only for input strings.

Sample request: F55<CR>  
 Response: F55 METERS<CR><LF>

To select feet send the following character string:

Sample entry: F55<SP>FEET<CR>  
 Response: OK<CR><LF>

Sample request: F55<CR>  
 Response: F55 FEET<CR><LF>

### **3-256 SERIAL FUNCTION F56 - AVERAGE POSITION ENTRY/REQUEST**

Use Serial function F56 to enter or request the averaged, hence accurate, current antenna position. Its main use is to provide a means of setting an accurate, surveyed position for use in the TIME mode of operation. Positions provided to the XL-AK via function F56 should be more accurate than 10 meters, otherwise better results may be obtained via AUTO mode, unless satellite visibility at the site is too poor to provide three dimensional positioning.

The as shipped default position is S 00d00'0.0" W 000d00'0.0". The position at power-up will be the same as it was prior to power-down. An averaged position as returned via function F56 which subsequently becomes in error by more than 1 km, either due to transport of the receiver and antenna or error in the initial entry, will be cleared and recalculated automatically once positioning begins at the new site and the error is detected.

To determine the present position send F56<CR> and the Serial port will respond with the following continuous one line string:

F56<SP><SIGN><SP><DEG>d<MIN>'<SEC>"<SP><SIGN><SP><DEG>d<MIN>'<SEC>"<SP><SP><SP><SP or -> <ALT><UNITS><SP><SOURCE><LT>

where:

F = ASCII character F (f or F for input string).  
 56 = function number.  
 <SP> = ASCII space character.  
 <SIGN> = N or S for latitude; E or W for longitude; or + or - for longitude, latitude or altitude (-) corresponds to S or W, or no character, <SP> for + altitude.  
 <DEG> = two-digit degrees for latitude or three-digit degrees for longitude.  
 d = ASCII character d (d or D for input string -- always d in output string).  
 <MIN> = two-digit minutes.  
 ' = ASCII character '(' or m or M for input string -- always ' in output strings).  
 <SEC> = two-digit seconds + 1 digit 10ths of seconds.  
 " = ASCII character "(" s or S for input string -- always " in output string).  
 <ALT> = altitude in feet or meters.

<UNITS> = unit of altitude, either a M or m for meters or F or f for feet depending on the units selected with Serial function F55.

<SOURCE> = the source of the position in one of two formats:  
COUNT <NNNNN> / 90000  
NNNNN is the total number of fixes in the average, 90000 is the total number of fixes required to complete the position average process.  
ENTERED  
Indicates that the current averaged position was obtained via operator entry.

<LT> = line terminator, either a carriage return and line feed for output strings or carriage return only for input strings.

Sample request: F56<CR>  
Response: F56 N 38d23'51.3" W 122d42'53.2" 58m 49001/90000<CR><LF>

To enter a position send a character string with the following format. Latitude, longitude or altitude may be omitted in the string provided they are replaced with a semicolon (;) character. The altitude units may be feet or meters. **The unit must be in TIME mode to enter the accurate position using F56.**

Sample entry: f56 n 38d23'51.3" w 122d42'53.2" 10m<CR>  
equivalent: F56 + 38D23M51.3S + 122D42M53.2S +10M<CR>  
Response: OK<CR><LF>

Sample request: F56<CR> (after sending above string)  
Response: F56 N 38d23'51.3" W 122d42'53.2" 10m ENTERED<CR><LF>

Sample entry: f56 ; ; 40m (with values from example above)  
(no change to latitude or longitude - altitude now 40m)  
Response: OK<CR><LF>

Sample request: F56<CR>  
Response: F56 N 38d23'51.3" W 122d42'53.2" 40m<CR><LF>

NOTE: Altitude must be included in the position entry string - either a value or a (;) must be entered or a syntax error will occur (causing the entered string to be ignored).

3-257 through 3-259 reserved

### **3-260 SERIAL FUNCTION F60 - SATELLITES LIST REQUEST**

Use Serial function F60 to request a list of all, current, tracked or bad satellites. To request the list send the string:

F60<SEP><TYPE><CR>

where:

F	=	ASCII character F.
60	=	function number.
<SEP>	=	one or more separator characters; either space, comma or tab.
<TYPE>	=	ALL, CURRENT, TRACKED or BAD.
<CR>	=	carriage return character.

The Serial port will respond with a series of strings of the form:

F60 prn <NN> good enabled tracked current sig level= <+or -><LEVEL><CR><LF>

where:

<NN>	=	two-digit satellite number.
Tracked	=	either present or absent.
Current	=	either present or absent.
<+ or ->	=	+ means sat tracked / - means sat dropped.
<LEVEL>	=	satellite signal quality.
<CR>	=	carriage return character.
<LF>	=	line feed character.

Sample request: F60 ALL<CR>

Response:

F60 prn 14 good enabled tracked current sig level	=	+12.00<cr><lf>
F60 prn 15 good enabled tracked current sig level	=	+8.55<cr><lf>
F60 prn 18 good enabled tracked current sig level	=	+8.73<cr><lf>
F60 prn 19 good enabled sig level	=	+0.00<cr><lf>
F60 prn 11 good enabled sig level	=	+0.00<cr><lf>
F60 prn 2 good enabled sig level	=	+0.00<cr><lf>
F60 prn 23 good enabled sig level	=	+0.00<cr><lf>
F60 prn 21 good enabled tracked sig level	=	+7.19<cr><lf>

3-261 through 3-264 reserved

### **3-265 SERIAL FUNCTION F65 - SATELLITE SELECT**

Use Serial function F65 to select specific satellites for the receiver to track or to deselect, i.e instruct the XL-AK to ignore certain satellites. Send the string of the form:

F65<SEP><REQUEST><SEP>NN<SEP>NN<SEP>NN<CR>

or

F65<SEP><REQUEST>ALL<CR>

where:

F	=	ASCII character F.
65	=	function number.
<REQUEST>	=	either SELECT or DESELECT
<SEP>	=	one or more separator characters; either space, tab or comma.
NN	=	two-digit satellite number.
ALL	=	ASCII character string ALL.
<CR>	=	carriage return character.

Sample entry: F65 SELECT 02 18 13<CR>  
Response: OK<CR><LF>

Sample entry: F65<SP> SELECT ALL<CR>  
Response: OK<CR><LF>

Sample entry: F65 DESELECT 01 08<CR>  
Response: F65 OK<CR><LF>

To determine which satellites are enabled or disabled and being tracked use Serial function F60. Only those satellite numbers appearing on the Satellite List as displayed using F60 may be selected or deselected. Use of any other satellite number will result in the error message "ERROR 04 EXCLUSIVE USE".

NOTE: The XL-AK Receiver requires 24 hours after turn on to complete the satellite list.

### **3-266 SERIAL FUNCTION F66 - DAYLIGHT SAVING ENABLE**

Use Serial function F66 to enable or disable or set the entry or exit times for DST. The as shipped default is "Off". The default on power-up will be the selection in use just prior to power-down.

To request the present status of the daylight saving enable, send F66<CR> to the Serial port. The port will respond with the ASCII character string:

F66<SEP><STATE><LT>

where:

F	=	ASCII character F.
66	=	function number
<SEP>	=	one or more separator characters; either space, comma or tab.
<STATE>	=	Off or Manual.
<LT>	=	line terminator, either a carriage return and line feed for output strings or a carriage return only for input strings.

If the DST function is in Manual, the port will respond with the longer string described below.

Sample request: F66<CR>  
Response: F66 OFF<CR><LF>

Sample entry: F66<SP>Off<CR>  
Response: OK<CR><LF>

To place the DST function in Manual and set the DST entry and exit times send a continuous string of the form:

F66 MANUAL <IN HOUR><SEP><IN WEEK><SEP><IN DAY><SEP><IN MONTH><OUT HOUR>  
<SEP><OUT WEEK><SEP><OUT DAY><SEP><OUT MONTH><LT>

where:

<IN HOUR>	=	time to enter DST in 24-hour format.
<SEP>	=	one or more separator characters, either space comma or tab characters. For output strings this will be a single space character.
<IN WEEK>	=	which week to enter DST, 1, 2, 3, 4 or 0 (for last).
<IN DAY>	=	day of week to enter DST, 1 through 7 where Sunday is 1.
<IN MONTH>	=	month to enter DST, 1 through 12 where 1 is January.
<OUT HOUR>	=	hour to exit DST, in 24 hour format.
<OUT WEEK>	=	which week to exit DST, 1, 2, 3, 4 or 0 (for last).
<OUT DAY>	=	day in to exit DST, 1 through 7 where Sunday is 1.
<OUT MONTH>	=	month to exit DST, 1 through 12 where 1 is January
<LT>	=	line terminator, a carriage return and line feed for output strings, only a carriage return for input strings.

If desired, any item may be replaced with a semicolon, which will leave its value unchanged. If any of the items in an input string are invalid, an error message will be returned.

Sample Request: F66<CR>  
Response: F66 MANUAL 02 1 1 04 02 0 1 10  
Meaning: Manual settings are in effect. The entry time is 02 a.m. on the first Sunday of April and the exit time is 02 a.m. on the last Sunday in October.

Sample Entry: F66 MANUAL ; 0 ; ; ; ; ; <CR>  
Response: OK<CR><LF>  
Meaning: DST will now be entered on the last week of the month. All other parameters remain unchanged.

Sample Entry: F66 MANUAL 4 2 2 3 13 4 6 11<CR>  
Response: OK<CR><LF>  
Meaning: DST will now be entered 04 a.m. on the 2nd Monday in March and exit DST at 01 p.m. on the 4th Friday in November.

3-267 reserved

### **3-268 SERIAL FUNCTION F68 - YEAR ENTRY (GPS EPOCH MANAGEMENT)**

The GPS week number sent from the satellites has only 10 bits of precision, so that 1024 weeks from January 6, 1980 (GPS week 0) it rolls back to 0. To correctly calculate calendar dates after this roll point, firmware keeps track of the current year so that it can construct an absolute, non-rolling week number since January 6, 1980.

The firmware has the current year embedded in code, and will properly handle dates through the year 2015. In addition, as the clock advances to each new year, the current year is updated and used in future calendar calculations, thus calculations beyond 2015 are handled properly. No user intervention is required as long as the current year saved in non-volatile memory is intact, and so long as the clock runs locked to GPS at least once each 5 years to allow the year to be updated. If after 2015, the current year saved in non-volatile memory is lost, or the clock is not locked to GPS within 5 years of the last year saved in non-volatile memory, then Function 68 can be used to manually enter the current year. Years prior to 1996 are not accepted, and entering a future year may cause incorrect calendar date calculations.

To request the current year setting via Function 68, send the string:

Sample request: F68<CR>  
Response: F68 1996<CR><LF>

To set the current year, send a string with the following format:

Sample entry: F68 1997<CR>  
Response: OK<CR><LF>

### **3-269 SERIAL FUNCTION F69 - SELECT LOCAL/STANDARD/GPS/UTC TIME**

The as shipped default is UTC. The default at power-up will be the selection in use prior to power-down. Four time types are available for use.

Local Time modifies UTC time to include the Time Zone and Daylight Saving Time adjustments, if enabled by the user.

Standard Time modifies UTC time to include the Time Zone adjustment if enabled by the user.

GPS Time is defined by and derived directly from the GPS constellation with no leap second or other GPS to UTC corrections.

UTC Time is Universal Coordinated Time and differs from GPS Time by the addition of leap seconds and the A0 and A1 sub-second corrections.

Standard & Local time requires the setting of the local Time Zone offset with F01, (Set Time Zone).

Local time requires the setting of Daylight Saving Time with F66, (Daylight Saving Enable).

Use Serial function F69 to request or set the XL-AK time format. To request the current time type used, send F69<CR> to the Serial port. The port will respond with the following character string:

F69<SEP><HH><LT>

Sample request: F69<CR>  
 Response: F69 STANDARD <CR><LF>  
 or F69 LOCAL <CR><LF>  
 or F69 UTC <CR><LF>  
 or F69 GPS <CR><LF>

To set the Time Type:

F69<SEP><TT><LT>

where:

F = ASCII character F.  
 69 = function number.  
 <SEP> = one or more separator characters; either space, comma or tab.  
 <TT> = Time Type. Either STANDARD, LOCAL, GPS or UTC.  
 <LT> = line terminator, either a carriage return and line feed for output strings or a carriage return only for input strings.

Sample request: F69 STANDARD<CR>  
 Response: OK<CR><LF>

Sample request: F69 UTC<CR>  
 Response: OK<CR><LF>

3-270 reserved

### **3-271 SERIAL FUNCTION F71 - OSCILLATOR STATISTICS REQUEST**

Use Serial function F71 to request the internal or optional external (when operating in External Oscillator enabled mode, see function F07) oscillator's phase, frequency offset, drift rate and DAC value. The phase is the instantaneous error in seconds between the oscillator and the control loop zero servo point. The frequency offset is computed using an averaging time that is equal to the effective averaging time of the oscillator controller. The oscillator drift rate is computed using a 24 hour average and is the daily drift rate of the oscillator. The oscillator DAC value is the signed 16 bit integer which controls the DAC output voltage. It ranges from 32767 to -32768. Send the string F71<CR> to the Serial port and it will respond with the following continuous string:

F71<SP>phase=<SIGN><MULT>E<SIGN><EXP><SP>s<SP><SP>offset=<SIGN><MULT>E<SIGN><EXP><SP><SP>drift=<SIGN><MULT>E<SIGN><EXP>/DAY<SP><SP>DAC=<SIGN><INT><CR><LF>

where:

F = ASCII character F.  
 71 = function number.  
 <SP> = ASCII space character.  
 <MULT> = multiplier, 4 digits with decimal point.  
 E = ASCII character E for exponent.  
 s = ASCII character s for seconds abbreviation  
 <SIGN> = - for negative or <SP> for positive.  
 <EXP> = 2 digit exponent.

/DAY	=	ASCII characters, units of drift rate
<INT>	=	integer, 5 digits
<CR>	=	carriage return.
<LF>	=	line feed.

Sample request: F71<CR>  
 Response: F71 phase=-5.678E-09 s offset=-1.986E-07 drift= 6.013E-08/DAY DAC=  
 24567<CR><LF>

### **3-272 SERIAL FUNCTION F72 - FAULT STATUS REQUEST**

This function displays the current status of faults in the XL-AK sub-systems. Currently, the status of the antenna, PLL synthesizer lock status and the GPS lock status are the only such faults being monitored. The faults indicated here contribute to the state of the summary alarm open collector output and should be checked via F72 whenever an alarm output is detected.

Send the string F72<CR> and the serial port will respond with the following:

F72<SEP>Antenna: <ANT STATUS> PLL: <PLL STATUS> GPS: <GPS STATUS><CR><LF>

where:

F	=	ASCII character F
72	=	function number
<SEP>	=	one or more separator characters; either space, comma or tab
<ANT STATUS>	=	OK, OPEN or SHORT
<PLL STATUS>	=	OK, UNLOCKED
<GPS STATUS>	=	LOCKED, UNLOCKED
<CR>	=	ASCII carriage return character
<LF>	=	ASCII line feed character

### **3-273 SERIAL FUNCTION F73 - REQUEST/SET ALARM STATUS/CONTROL**

This function allows the user to control which conditions will signal an alarm or fault through the 87-8XX GPS-XL open collector output (OPTION) or through relay contacts (OPTION) on the 86-690 "L" board (if installed). The user may also monitor the status of the individual indicators which may contribute to the summary alarm output. In addition, the user may monitor the status of a latched version of the individual fault indicators which will show whether transient faults are occurring.

The fault status flags can be read by the following command, regardless of whether the faults are enabled or not:

F73<CR>

which returns:

F73<SP>S12345678<SP>M12345678<SP>m12345678<CR><LF>



where:

F	=	ASCII character F
7	=	ASCII character 7
3	=	ASCII character 3
<SP>	=	ASCII space character
S	=	'S' Status delimiter
1	=	'L' Satellite Lock OK
		'U' Unlock Spec Reached
2	=	'A' Position Accurate, Full Accuracy and Stability When Locked
		'B' Position Approximate, Slightly Degraded Accuracy and Stability When Locked
		'C' Position Unknown, Highly Degraded Accuracy and Stability, Not Locked
		'D' Position and Time Unknown, Not Locked
3	=	'A' Auto Mode
		'T' Time Mode
		'S' Survey Mode
		'D' Differential Mode
4	=	'0' Number of Current Satellites used in solutions thru
		'6'
5	=	'N' No timing source
		'G' GPS is timing source
		'F' AUX is timing source
		'I' IRIG is timing source
6	=	'.' Currently not used
7	=	'.' Currently not used
8	=	'.' Currently not used
M	=	'M' Major Alarm delimiter
1	=	'.' PLL Synthesizer OK
		'P' PLL Synthesizer Unlocked
2	=	'.' Antenna OK
		'O' Antenna Open
		'S' Antenna Short
3	=	'.' Receiver OK
		'R' Receiver Fault
4	=	'.' Non-Volatile RAM Data OK
		'N' Non-Volatile RAM Data Fault
5	=	'.' The minor alarm, 'Time Error Threshold Reached', has not persisted for Timeout seconds.
		'U' The minor alarm, 'Time Error Threshold Reached', has persisted for Timeout seconds.
6	=	'.' Currently not used
7	=	'.' Currently not used
8	=	'.' Currently not used
m	=	'm' Minor Alarm delimiter
1	=	'.' Time Error Threshold Not Reached
		'U' Time Error Threshold Reached
2	=	'.' Tracking OK
		'T' Not Tracking Satellites
3	=	'.' Oscillator Tuning Voltage OK

4	=	'X'	Oscillator Tuning Voltage Requires Adjustment
		'.'	Non-Volatile RAM Battery Voltage OK
		'B'	Non-Volatile RAM Battery Voltage Low
5	=	'.'	Unit has locked at least once.
		'a'	Unit has not locked since power on but is still within the user defined power-on time-out.
		'A'	Initial Acquisition Mode, unit has not yet locked since power on.
6	=	'.'	Currently not used
7	=	'.'	Currently not used
8	=	'.'	Currently not used
<CR>	=		ASCII carriage return character
<LF>	=		ASCII line feed character

Sending:

```
F73<SP>LATCH<CR>
```

returns:

```
F73<SP>LATCH<SP>M12345678<SP>m12345678<CR><LF>
```

which shows the latched faults, if any, which have occurred since the last time that the latch was cleared. These may or may not continue to be present in the non-latched indications.

Sending

```
F73<SP>CLEAR<SP>ALARM<SP>LATCH<CR>
```

will clear the latched fault indicators.

The user can query or control which faults affect the alarm output by the following commands. When setting the mask, the letter 'E' enables the fault, the letter 'D' disables it, and a '.' leaves it unchanged.

Sending:

```
F73<SP>MASK<CR>
```

returns:

```
F73<SP>MASK<SP>M12345678<SP>m12345678<CR><LF>
```

Sending:

```
F73<SP>MASK<SP>M12345678<SP>m12345678<CR>
```

sets the alarm mask where the mask characters are:

M	=	'M'	Major Alarm delimiter
1	=	'E'	PLL Synthesizer Alarm Enabled
		'D'	PLL Synthesizer Alarm Disabled
2	=	'E'	Antenna Alarm Enabled
		'D'	Antenna Alarm Disabled
3	=	'E'	Receiver Alarm Enabled
		'D'	Receiver Alarm Disabled
4	=	'E'	Non-Volatile RAM Data Alarm Enabled
		'D'	Non-Volatile RAM Data Alarm Disabled
5	=	'E'	The minor alarm, 'Time Error Threshold Reached', has persisted for Timeout seconds, Alarm Enabled
		'D'	The minor alarm, 'Time Error Threshold Reached', has persisted for Timeout seconds, Alarm Disabled
6	=	' '	Currently not used
7	=	' '	Currently not used
8	=	' '	Currently not used
m	=	'm'	Minor Alarm delimiter
1	=	'E'	Time Error Threshold Reached Alarm Enabled
		'D'	Time Error Threshold Reached Alarm Disabled
2	=	'E'	Tracking Alarm Enabled
		'D'	Tracking Alarm Disabled
3	=	'E'	Oscillator Tuning Voltage Alarm Enabled
		'D'	Oscillator Tuning Voltage Alarm Disabled
4	=	'E'	Non-Volatile RAM Battery Voltage Alarm Enabled
		'D'	Non-Volatile RAM Battery Voltage Disabled
5	=	'E'	Initial Acquisition Mode Alarm Enabled
		'D'	Initial Acquisition Mode Alarm Disabled
6	=	' '	Currently not used
7	=	' '	Currently not used
8	=	' '	Currently not used

The command returns:

```
OK<CR><LF>
```

if successful.

The time error threshold at which the time error fault is activated can be queried or set by the following command.

Sending:

```
F73<SP>THRESHOLD<CR>
```

returns:

```
F73<SP>THRESHOLD<SP><nanoseconds><SP>ns<CR><LF>
```

where <nanoseconds> is the time error threshold in nsec.

Sending:

F73<SP>THRESHOLD<SP><nanoseconds><CR>

sets the time error threshold and returns:

OK<CR><LF>

if successful.

The timeout after which a time error fault becomes a timeout fault can be queried or set by the following command.

F73<SP>TIMEOUT<CR>

which returns:

F73<SP>TIMEOUT<SP><seconds><SP>s<CR><LF>

where <seconds> is the timeout in seconds, between 0 and 86400.

Sending:

F73<SP>TIMEOUT<SP><seconds><CR>

sets the timeout and returns:

OK<CR><LF>

if successful.

If a checksum error is detected while recalling settings from non-volatile RAM, an NVRAM data fault is indicated. This same fault is active if an attempt was made to recall non-volatile RAM settings and default settings were created since no settings were found. This can occur if the non-volatile RAM battery is low or jumper JP1 is removed. An NVRAM fault is indicated since the operator should check the non-volatile settings to verify that they are correct. After the operator has confirmed that all settings are correct, the following command can be used to cancel the error, so that future errors can be caught.

F73<SP>CLEAR<SP>NVRAM<SP>FAULT<CR>

clears the fault and returns:

OK<CR><LF>

XL-AK's have a front panel Red/Green Status LED that is controlled by function 73. In general, faults only affect the Status LED if they are enabled. However, even if there is no enabled major or minor fault, the presence of the time error fault is indicated by a solid Green Status LED if BLINK = ENABLE (default). Normal operation within the user-defined time error threshold is indicated by the Green LED blinking at a one pulse per second rate.

The Red/Green Status LED has the following states (when BLINK = ENABLE):

Off	Power off
Solid Red	Major enabled alarm fault
Solid Orange	Minor enabled alarm fault, time error outside threshold.
Blinking Red/Orange	Minor enabled alarm fault, time error within threshold.
Solid Green	No enabled alarm faults, time error outside threshold.
Blinking Green	No enabled alarm faults, time error within threshold.

The Red/Green Status LED has the following states (when BLINK = DISABLE):

Off	Power off
Solid Red	Major enabled alarm fault
Solid Orange	Minor enabled alarm fault
Solid Green	No enabled alarm faults

In all implementations using the 87-8XX GPS-XL Module, the open collector alarm output has the following states:

Off (High Z)	Power off
Off (High Z)	Error, major or minor enabled alarm fault.
On (Low Z)	Normal, no major or minor enabled alarm faults.

If the processor on the 87-8XX GPS-XL Module were to fail, resulting in a failure to trigger the watchdog timer, the watchdog timer would reset the processor and attempt to restart the system. During the processor reset, the Status LED output would be Red, and the alarm output transistor open collector would be off, indicating a fault. If the processor were unable to recover and resume triggering the watchdog timer, a succession of watchdog timer timeouts followed by resets would result, producing a blinking Red Status LED. At the same time, the open collector alarm output transistor might either be off, or might toggle between off and on following the repeated resets, indicating an alarm condition.

LED BLINKING can be ENABLED or DISABLED in all but the processor reset condition.

Sending:

```
F73<SP>BLINK ENABLE<CR>
```

enables the LED to blink under the conditions given above. The response is:

```
OK<CR><LF>
```

if successful.

Sending:

```
F73<SP>BLINK DISABLE<CR>
```

disables the LED from blinking in all but the processor reset mode as given above.

Minor Alarm conditions may be delayed if power-on Minor Alarm SUPPRESS is set to a value (in seconds). The Minor Alarms will be suppressed until either the unit power-on time exceeds the Minor Alarm suppress time or the unit locks to GPS.

The power-on Minor Alarm suppress time can be read by the following command:

```
F73<SP>SUPPRESS<CR>
```

which returns:

```
F73<SP>POWER-ON<SP>MINOR<SP>ALARM<SP>SUPPRESS<SP><seconds><SP>s<CR><LF>
```

where:

F	=	ASCII character F.
73	=	function number.
<seconds>	=	seconds from 0 to 86400.
<SP>	=	ASCII space character.
<CR>	=	Carriage Return.
<LF>	=	Line Feed.

The Minor Alarm suppression power-on timeout can be set by the following command:

```
F73<SP>SUPPRESS<SP><seconds><CR>
```

The seconds can be set to any value from 0 to 86400 which sets the suppress time and returns:

```
OK<CR><LF>
```

if successful.

3-274 through 3-278 reserved

### **3-279 SERIAL FUNCTION F79 - WARM START**

This function issues a reset command to the Trimble SVeeSix GPS core module. It does not clear stored almanac and ephemeris data which are retained in battery-backed RAM.

Send the string F79<CR> and the serial port will respond by initiating a warm start.

Sample entry: F79<CR>  
Response: OK<CR><LF>

## SECTION V

### 86-690 OUTPUT CONFIGURATION "L" BOARD

#### **5-1 86-690 "L" BOARD INTRODUCTION**

The 86-690 Output Configuration Board "L" Board may or may not be installed in your unit -- refer to the Installed Options Checklist in the front of the manual. This board allows the user to select one of several analog or digital signals that will appear at five rear panel BNCs labeled J1 through J5. Signal selection is made by the installation of jumpers. Each BNC output has an associated header strip on the option board. Each header strip requires two, 2-pin jumpers. One jumper defines the signal format and the second jumper selects the appropriate analog or digital driver. See installation instructions for detailed information.

#### **5-2 SIGNAL SPECIFICATIONS**

Analog Output Drive:

Amplitude: 1 V rms into 50 ohms  
Connector: Female BNC

Analog Output Format Description - the following output formats are available:

IRIG B AM	IRIG B amplitude modulated
OPT IRIG H AM	IRIG H amplitude modulated (optional)
OPT IRIG E AM	IRIG E amplitude modulated (optional)

Digital Output Drive:

Amplitude: +2.5 Vdc into 50 ohms (+/-24 ma), (0 to +5 Vdc Open Circuit)  
Connector: Female, BNC

Alarm Relay Specifications (OPTION)

Contacts: 1 Form C  
Max Voltage: 48 VAC/Vdc  
Max Current: 2A @ 24 Vdc

Digital Output Format Description:

IRIG B 001, IRIG H 001, and IRIG E 001 - These are the DC Shift formats of IRIG B, H, and E time code.

ALARM - This output level is asserted by various programmable alarm conditions such as timing error during loss of lock or antenna shorts. Programming is described in the manual section titled: KEYPAD FUNCTION F73 - DISPLAY/SET ALARM STATUS/CONTROL and SERIAL FUNCTION F73 - REQUEST/SET ALARM STATUS/CONTROL.

PROGPULSE - The Programmable Pulse Output allows the generation of a precisely synchronized trigger pulse at an arbitrary time and with arbitrary pulsewidth in integer multiples of 1 ms. The rising edge of the trigger output may be programmed to occur with 1 ms

resolution and will be within 150 ns of the UTC millisecond. Programming is done via the serial port. Refer to “SERIAL FUNCTION F26 - PROGRAMMABLE PULSE OUTPUT” (in Section III) for details of the programming of this output pulse.

PUSLE RATES - 1 PPS, 1 KPPS, 10 KPPS, 1 MPPS, 10 MPPS - These pulse rate outputs have a 50 percent duty cycle with their rising edge “on-time.”

SPCL 1 THROUGH SPCL 4 - The Special Output signals are digital outputs reserved for special timing applications.

### **5-3 SIGNAL CONFIGURATION**

Signal configuration requires the removal of the top cover to gain access to selection jumpers. The only equipment required for installation is a Phillips screwdriver.

**CAUTION: Remove the AC Power connector before removing the top cover. This instrument contains high voltage which can cause electric shock that could result in severe injury or even death.**

Remove the screws located on the sides of the chassis. Remove the top cover. Locate the jumper header rows which are shown in Figure 1. There are five 20-pin header rows identified as CONFIG J1 through CONFIG J5. These correspond to BNCs J1 through J5 on the rear panel. Two header jumpers are required for each output. One jumper selects the signal format such as IRIG B or 1PPS and a second jumper selects the appropriate output driver such as analog (ANALDRV) or digital (DIGDRVR). Only the amplitude modulated outputs (IRIG B AM, optional IRIG H AM and IRIG E AM) require the analog driver. All other outputs require the digital driver.



FIGURE 1

CONFIGURATION HEADER

	<u>J1</u> <u>CONFIG</u>	<u>J2</u> <u>CONFIG</u>	<u>J3</u> <u>CONFIG</u>	<u>J4</u> <u>CONFIG</u>	<u>J5</u> <u>CONFIG</u>
IRIG B AM	• •	• •	• •	• •	• •
OPT IRIG H AM	• •	• •	• •	• •	• •
OPT IRIG E AM	• •	• •	• •	• •	• •
IRIG B 001	• •	• •	• •	• •	• •
IRIG H 001	• •	• •	• •	• •	• •
IRIG E 001	• •	• •	• •	• •	• •
ALARM	• •	• •	• •	• •	• •
PROGPULSE	• •	• •	• •	• •	• •
1PPS	• •	• •	• •	• •	• •
1KPPS	• •	• •	• •	• •	• •
10KPPS	• •	• •	• •	• •	• •
100KPPS	• •	• •	• •	• •	• •
1MPPS	• •	• •	• •	• •	• •
10MPPS	• •	• •	• •	• •	• •
SPCL 1	• •	• •	• •	• •	• •
SPCL 2	• •	• •	• •	• •	• •
SPCL 3	• •	• •	• •	• •	• •
SPCL 4	• •	• •	• •	• •	• •
ANALDRV	• •	• •	• •	• •	• •
DIGDRVR	• •	• •	• •	• •	• •

Optional IRIG E & H AM Output Code Adjustments - The optional outputs should normally not require adjustment. They are adjusted at the factory for a signal level of 1 volt rms into a 50 ohm load. The outputs are adjusted for a mark to space ratio of 3 to 1.

- R10 - IRIG H amplitude
- R11 - IRIG E amplitude
- R13 - IRIG E ratio
- R14 - IRIG H ratio
- R17 - IRIG H and IRIG E phase (adjust for minimum discontinuity between high and low amplitude carrier signals)

**5-4 GENERAL OPERATION**

Once the jumper installation is complete, the outputs are automatically enabled upon power-up and output continuously. If an output should not appear to operate properly be sure that the jumper selection for the driver output type (ANALDRV or DIGDRVR) is correct for the signal format selected. Also, some outputs such as the Programmable Pulse and the Alarm output require program setup to be enabled.

## **5-5 THEORY OF OPERATION**

Reference schematic 86-690, sheet 2. This circuitry shows the header strip jumpers and the analog and digital drive logic for BNC outputs J1 through J4. U15 and U17 are dual analog drivers. U18 is an octal digital driver.

Reference schematic 86-690, sheet 3. This drawing shows the jumper header strip, analog, and digital driver for BNC J5. U19 is the analog driver and U18 is the digital driver. Timing outputs are written each millisecond to latch U3. These outputs are switched out on the next 1 KPPS clock from U4. This output latch provides the signals IRIG E DC Shift, IRIG H DC Shift, Programmable Pulse and Special Outputs 1 through 4. The programmable logic device at U11 provides address decode logic to allow the GPS-XL to write to the front panel display and read keyboard input. It also outputs a strobe signal to retrigger one-shot U14. The strobe is turned off when an "ALARM" condition is asserted. This output is routed to the header strips and also drives the optional alarm relay, K1.

Reference schematic 86-690, sheet 4. This drawing shows the keyboard bus driver logic U1, and the keyboard decoder chip U2. Potentiometer R1 adjusts the viewing angle control voltage for the front panel LCD display.

Reference schematic 86-690, sheet 5. This drawing shows counter logic, which is used to divide the 1 MPPS clock down to 100 KPPS and 10 KPPS outputs. These clock outputs are synchronized to the 1 KPPS clock by dual flip-flop U5. The 1 KPPS clock drives the 1 KHz filter shown by components U12 and their surrounding capacitors and resistors. The output at U12 pin 7 is a 1 KHz sine wave. This signal is modulated to produce IRIG E AM and IRIG H AM. Modulation is achieved by using the DC Shift format of the codes to select an attenuated or non-attenuated level of the sine wave signal. Potentiometers R13 and R14 are used to control the ratio of IRIG E and IRIG H, respectively. U9 is an analog switch that is driven by the DC code format. Potentiometers R11 and R10 control the amplitude of each of the above formats.

© TrueTime, Inc. 2000 All Rights Reserved.

PROPRIETARY NOTICE

THIS DOCUMENT, WHETHER PATENTABLE OR NON-PATENTABLE SUBJECT MATTER, EMBODIES PROPRIETARY AND CONFIDENTIAL INFORMATION AND IS THE EXCLUSIVE PROPERTY OF TRUETIME, INC. IT MAY NOT BE REPRODUCED, USED OR DISCLOSED TO OTHERS FOR ANY PURPOSE EXCEPT THAT FOR WHICH IT IS LOANED, AND IT SHALL BE RETURNED UPON DEMAND.

REVISIONS

REV	DESCRIPTION	DATE	APPROVED
A	UPDATE TO NEW REV CHASSIS	4/21/97	MDK
B	ITEM 15 WAS 270-004-002	6/4/97	DR
C	CAR 830 & 694; ECO 1116; ADD 'FCC'	6/4/98	DR
D	CAR 618; CAR 1042; ECO 1181	10/29/98	DR
E	CAR 861	03/28/00	Drx

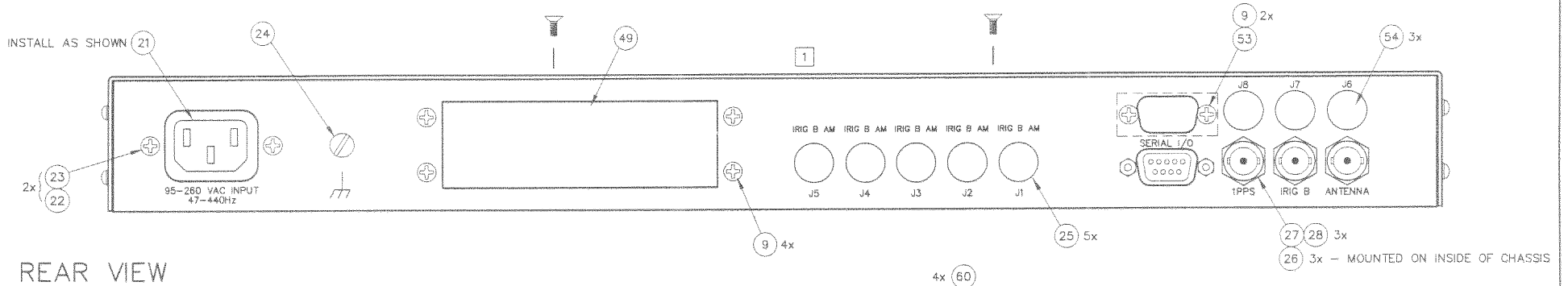

REAR VIEW

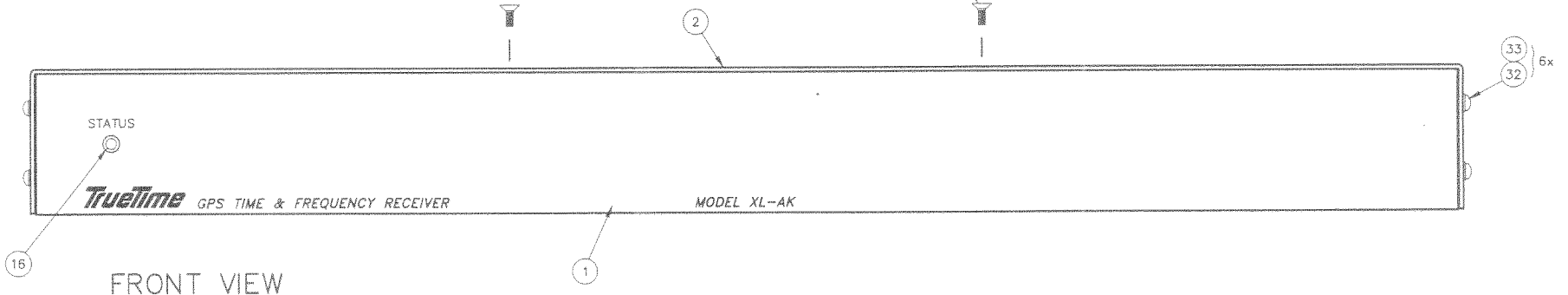

FRONT VIEW

2. WIRE ASSEMBLY PER WIRING DIAGRAM 600-000 (SHEET 3).

1 LABEL REAR PANEL AS SHOWN, UNLESS J1-J5 "CONFIG INFO" IS SPECIFIED OTHERWISE ON SALES ORDER.

NOTES: UNLESS OTHERWISE SPECIFIED.

FILENAME: \600\000A  
DATE: 03-28-00

CONTRACT NO.		 <small>"Where Customer Satisfaction is our Highest Priority" 2835 Duke Ct. Santa Rosa, CA 95407</small>			
APPROVALS	DATE				
DRAWN BY RKLEIN	4/96				
CHECKED BY					
APPROVED BY DR		11/98			
NEXT ASSY		SIZE	CODE IDENT NO.	DRAWING NO.	REV
		B		600-000	E
		SCALE NONE		SHEET 1 OF 3	

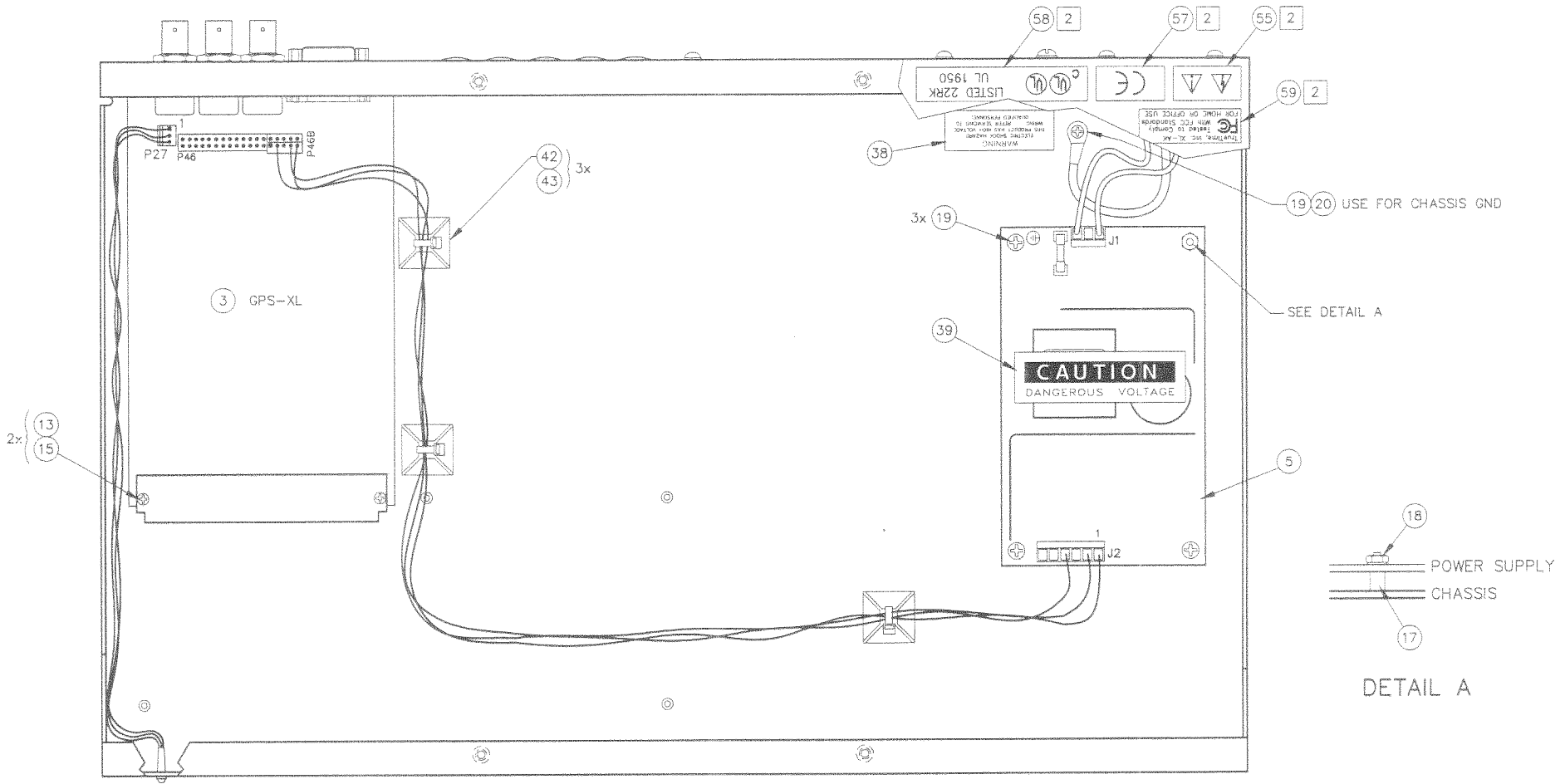

2 APPLY LABEL TO COVER WHERE SHOWN.

NOTES: CONT'D

FILENAME: \600\000B  
DATE: 03-28-00

<b>TrueTime</b> "Where Customer Satisfaction is our Highest Priority" 2835 Duke Ct. Santa Rosa, CA 95407			
SIZE	CODE IDENT NO.	DRAWING NO.	REV
B		600-000	E
SCALE NONE		SHEET 2 OF 3	

REAR PANEL

POWER RECEPTACLE

SEE NOTE 5

L  
G  
N

BRN  
GRN/YEL  
BLU

SEE NOTE 2

2x  
37  
36

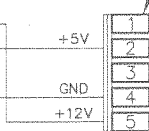
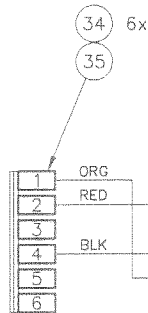
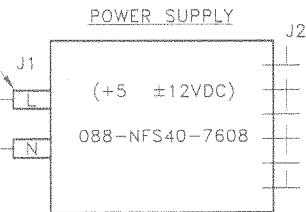

31 3X  
40

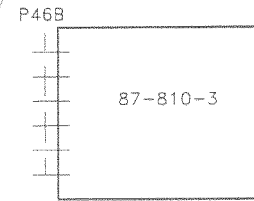

3X 31

30



FRONT PANEL

STATUS  
(LED)

5. ADD HEAT SHRINK TO AC POWER WIRES; WRAP AC POWER WIRES IN HEAT SHRINK TOGETHER.
4. ATTACH J-CLAMP (ITEM 41) AS NEEDED.
3. TWIST CABLE WIRES AS NEEDED.
2. CONNECT CHASSIS GROUND TO PEM NUT LOCATED AT THE REAR OF THE CHASSIS NEAR THE POWER RECEPTACLE USING ITEM 19 AND 20.

NOTES: (CONT.)

**TrueTime**  
"Where Customer Satisfaction is our Highest Priority"  
2835 Duke Ct. Santa Rosa, CA 95407

FILENAME: \600\000C  
DATE: 03-28-00

SIZE	CODE IDENT NO.	DRAWING NO.	REV
B		600-000	E
SCALE NONE		SHEET 3 OF 3	

## SECTION VIII

### IRIG-B, IRIG-H AND IRIG-E TIME CODE FORMATS

#### **8-1 INTRODUCTION**

The document 200-70 "IRIG STANDARD TIME FORMATS" by the Telecommunications Working Group, Inter-range Instrumentation Group, Range Commanders Council describes IRIG-B, IRIG-H and IRIG-E time codes. It is available by writing Secretariat, Range Commanders Council, White Sands Missile Range, New Mexico, 88002.

The standard time formats of IRIG codes were designed for use in missile, satellite and space research programs. Use of these codes facilitates efficient interchange of test data. These formats are suitable for recording on magnetic tape, oscillographs, film and for real-time transmission in both automatic and manual data reduction. IRIG-B from the Model XL-AK is suitable for remote display driving, magnetic tape recording and many other uses. IRIG codes, in the strict sense, encode Universal Coordinated Time (UTC) in 24-hour format and not local time. Nonetheless, this instrument can encode UTC or local time in either 24 or 12 hour formats.

#### **8-2 IRIG CODE FORMAT**

Reference figures 8-1, 8-2 and 8-3. The level shifted, pulse-width modulated, serial formats of IRIG-B, IRIG-H and IRIG-E are divided into three segments. The first segment encodes time-of-year in binary-coded-decimal (BCD) notation. The second segment encodes control functions. This segment is generally available for data of the user's choice. In the IRIG-B code output of Model XL-DC, this segment may encode worst-case time error flags as explained below. Neither the IRIG-H (OPTION) or IRIG-E (OPTION) output from Model XL-DC encode control functions. The third segment sometimes encodes time-of-day in straight binary seconds (SBS) notation. This segment is not encoded by the Model XL-DC.

These three segments are contained within one "frame". The frame length for IRIG-B is 1 second long and contains 100 "elements" (pulses) each of which start every 10 milliseconds. The frame length for IRIG-E is 10 seconds and contains 100 elements each of which starts every 100 milliseconds. The frame length for IRIG-H is 1 minute long and contains 60 elements each of which starts on the second.

An element may represent either a binary zero, a binary one, a reference marker or a position identifier. A zero is 0.2 of the duration of an element, a one is 0.5 of the duration of an element and a position identifier or reference marker is 0.8 of the duration of an element. A reference marker locates the beginning of each frame and a position identifier marks the end of every ten elements. IRIG-B and IRIG-E have ten position identifiers per frame and IRIG-H has six.

The elements prior to position identifier P5 comprise the time-of-year segment. The first ten elements encode the seconds, the second ten elements encode the minutes and so on through days. Each element is a digit in a binary number with a place value sequence 1-2-4-8.

### **8-3 EMBEDDED WORST-CASE TIME ERROR FLAGS**

Five flags are encoded in the control function segment of the IRIG-B code. The first flag encoded at element P5+40ms is the LOCK indicator. It is a binary 1 when the unit has lost contact with satellite signals. The second flag encoded at element P5+60ms is a binary 1 when the worst-case time error exceeds threshold 1 as described in SECTION III, "SERIAL I/O FUNCTION 05 - TIME QUALITY ENABLE/SETUP". Element P5+70ms is a binary 1 when the worst-case time error exceeds threshold 2. Element P5+80ms encodes a binary 1 when the error exceeds threshold 3 and P5+90ms when the error exceeds threshold 4.

8-4 through 8-9 reserved

### **8-10 SPECIAL IRIG-B TIME CODE FORMAT (EMBEDDED GPS DATA OPTION)**

GPS data may be encoded in the control function segment of the IRIG-B code. This data, along with the worst-case time error flags (STANDARD), are present in the IRIG-B code if this special option is ordered. This special IRIG-B format is used as a timing source for TrueTime's Model MAC-SG (560-5700).

Embedded GPS data is encoded between P6 and P0. One of five data items is encoded into each second, determined by the units of seconds as follows:

<u>UNITS OF SECONDS</u>	<u>GPS DATA</u>
0, 5	Latitude
1, 6	Longitude
2, 7	Altitude
3, 8	Year
4, 9	(spare)

**Figure 8-1 IRIG-B Time Code**

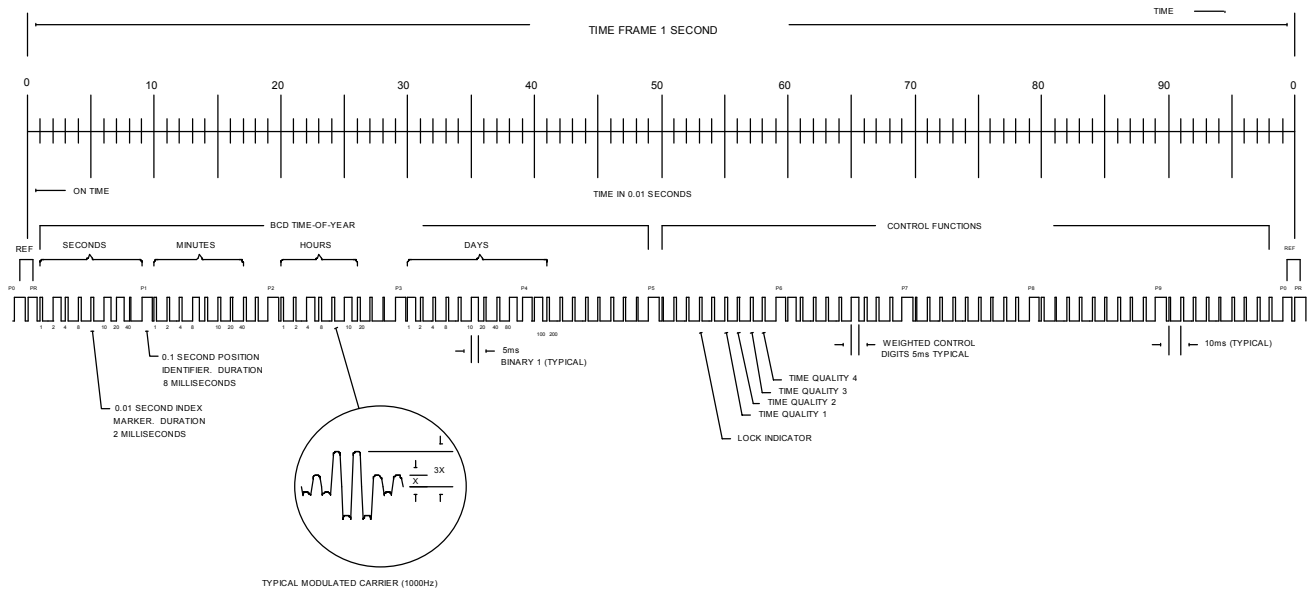

IRIG-B TIME CODE FORMAT

**Figure 8-2 IRIG-E Time Code**

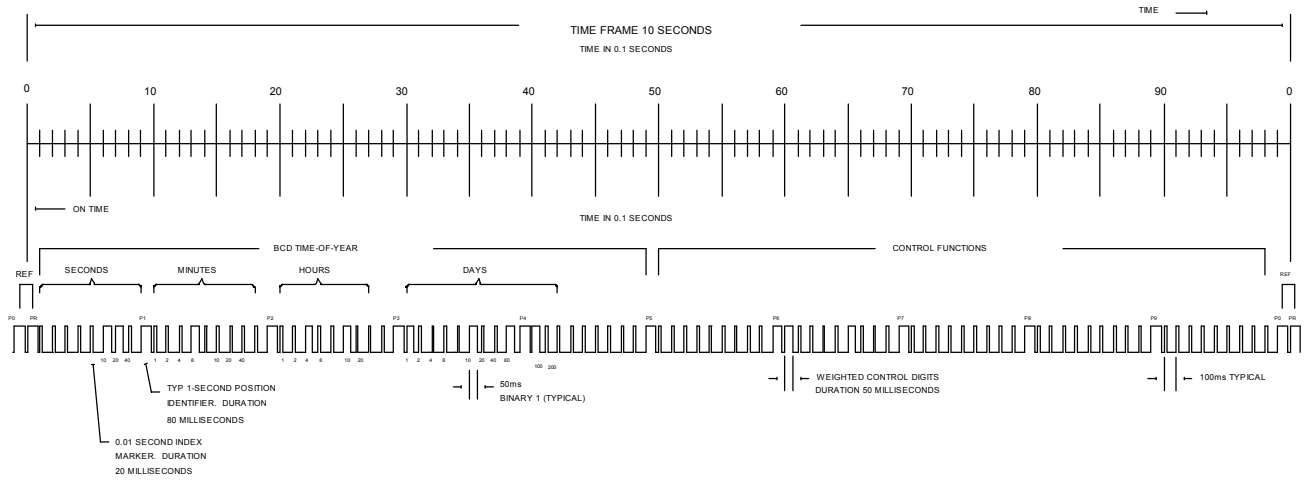

IRIG-E TIME CODE FORMAT



Figure 8-3 IRIG-H Time Code

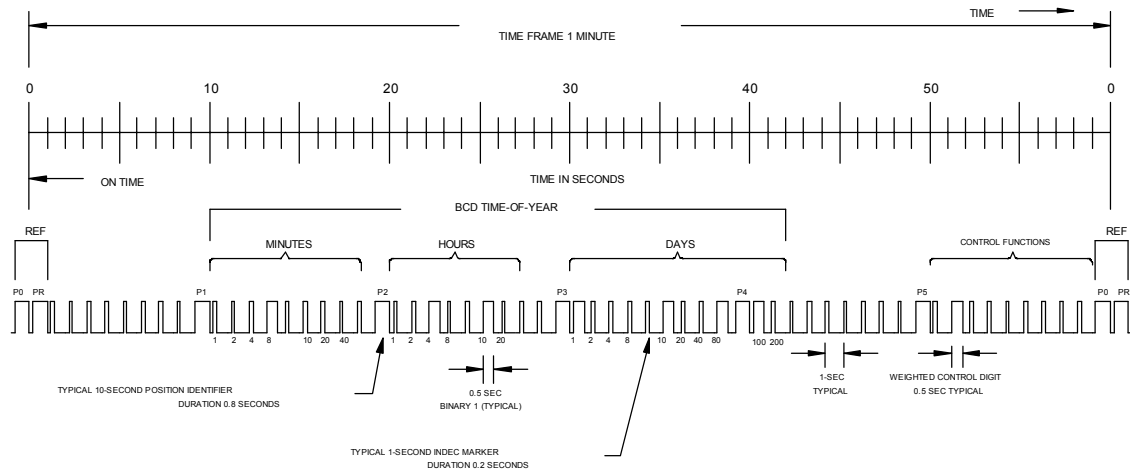

IRIG-H TIME CODE FORMAT